

AUS FREUDE AN

BADEA

COLLECTION



BADEA

eine vertraute Marke

Eintauchen und entspannen: badea eröffnet Spielräume, um Oasen des Wohlbefindens zu gestalten. Die Vielfalt und Langlebigkeit unserer Badausstattungen liegen uns am Herzen. Ob Komfortmöbel oder Waschtisch – badea verbindet Markenqualität mit langjähriger Erfahrung und einer verantwortungsvollen Fertigung in Ostwestfalen-Lippe in Deutschland. Viel Freude beim Planen!

A TRUSTED BRAND

Take a soak and relax: badea opens the door to creating havens of well-being. The variety and durability of our bathroom furnishings are priorities for us. Whether it's user-friendly, convenient furniture or washstand – badea combines brand quality with years of experience and responsible production in the Ostwestfalen-Lippe region in Germany. We hope you enjoy planning your new bathroom.

UNE MARQUE DE CONFIANCE

S'immerger et lâcher prise : badea ouvre de nouvelles perspectives pour créer un havre de paix. Pour nous, la diversité et la durabilité de l'aménagement de nos salles de bains sont essentielles. Qu'il s'agisse de meuble convivial ou de vasque, badea allie qualité, savoir-faire depuis de nombreuses années et fabrication responsable au cœur de la région Westphalie Est-Lippe (Allemagne). Prenez du plaisir à créer !

CLASSIC



22 – Vegas



28 – Contour



34 – Eden



36 – Verona



40 – Nordic



44 – Modena



50 – Pisa



52 – Bari



56 – Livorno



58 – Pisa



60 – Modena

PURE

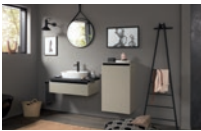

64 – Livorno



66 – Bari



70 – Bari

VARIPRO



80 – Organic 2.0



82 – Contour



86 – Contour



88 – Contour



90 – Cubus 2.0



94 – Cubus 2.0



96 – Futura 2



98 – Futura 2



100 – Organic



102 – Organic 2.0



106 – Roma



108 – Roma



110 – Roma

PLUS

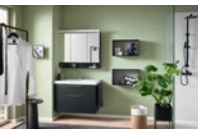

112 – Subway 2.0

VISIT



122 – Visit 4



128 – Bari



Online-Katalog
Online catalogue
Catalogue en ligne



Ausstellungszentrum Haus Beck
Haus Beck exhibition centre
Centre d'exposition Haus Beck

Erfahrung und TRADITION

Die Marke badea genießt seit über 25 Jahren unter Badgestaltern und Innenarchitekten einen ausgezeichneten Ruf. Eingebettet in die baumann group, die mit ihren Küchen weltweit erfolgreich ist, setzt badea auf Synergieeffekte und die geballte Erfahrung der Gruppe. Im historischen Ambiente des Hauses Beck, einem Rittergut mit über 800-jähriger Geschichte, präsentiert sich badea mit einer großzügigen Erlebniswelt in zeitgemäßer Planungsvielfalt.

EXPERIENCE AND TRADITION

The badea brand has enjoyed an excellent reputation among bathroom and interior designers for over 25 years. Embedded in the baumann group, successful with its kitchens across the globe, badea utilises synergies and the group's vast amount of experience. In the authentic ambience of Haus Beck, a manor with a history stretching back over 800 years, badea is presented in a lavishly orchestrated world of impressions showing a huge variety of planning options.

EXPÉRIENCE ET TRADITION

Depuis plus de 25 ans, la marque badea jouit d'une excellente réputation parmi des agences de salles de bains et les décorateurs d'intérieur. Intégrée au sein du baumann group, dont les cuisines sont connues dans le monde entier, badea table sur l'effet de synergie et sur un concentré d'expérience. Dans l'ambiance historique du manoir Haus Beck, vieux de plus de 800 ans, badea se présente dans un cadre digne de planifications contemporaines.



Virtueller Showroom
Virtual showroom
Showroom virtuel





Ausgezeichnete QUALITÄT

Als gewachsenes Familienunternehmen und Teil der baumann group agieren wir langfristig und investieren gezielt in moderne Fertigungsanlagen, effiziente Produktionstechniken und hohe Umweltstandards. Unsere Zulieferer wählen wir mit Bedacht und großer Sorgfalt aus.

QUALITY EXCELLENCE

As a long-established family business and part of the baumann group, we act with the future in mind and systematically invest in modern manufacturing facilities, efficient production techniques and high environmental standards. We select our suppliers with great care and consideration.

QUALITÉ EXCEPTIONNELLE

En tant qu'entreprise familiale et partie du baumann group, orientée vers l'avenir, nous investissons dans des chaînes de production modernes, des techniques de pointe et appliquons de sévères normes environnementales. Nos sous-traitants sont sélectionnés avec le plus grand soin et à bon escient.



GOLDENE M



Das „Goldene M“ der Deutschen Gütegemeinschaft Möbel e. V. gilt als strengster Qualitätsnachweis für Möbel in Europa und ist in diesem Bereich das einzige RAL-Gütezeichen in Deutschland. Unsere Möbel werden regelmäßig von unabhängiger Stelle geprüft. Das „Goldene M“ garantiert Ihnen die hohe Qualität unserer Bäder und steht für gesundes Wohnen.

GOLDENE M

The "Golden M" from the German Furniture Quality Assurance Association (Deutsche Gütegemeinschaft Möbel e.V. - DGM) is regarded as the most stringent proof of quality for furniture in Europe and is Germany's only RAL quality label in this segment. Our furniture undergoes regular inspection by an independent body. In other words, the "Golden M" guarantees you the high quality of our bathrooms and also provides a key to healthy home living.

« GOLDENE M »

Le « Goldene M », décerné par le Groupement allemand de Qualité des meubles [Deutsche Gütegemeinschaft Möbel e.V., DGM], est une preuve de qualité irréfutable pour les meubles en Europe et, dans ce domaine, le seul label RAL en Allemagne. Nos meubles sont régulièrement contrôlés par un organisme indépendant. Le « Goldene M » est donc le gage de qualité de nos salles de bains et d'habitat sain.

GEPRÜFTE SICHERHEIT



Mit dem weltweit anerkannten GS-Zeichen stellen wir sicher, dass unsere Produkte die Qualitäts- und Sicherheitsstandards des deutschen Produktsicherheitsgesetzes (kurz: ProdSG) erfüllen. Das GS-Siegel ist für Sie eine wertvolle Entscheidungshilfe beim Kauf. Auf die Qualität und Sicherheit unserer Produkte können Sie sich verlassen.

TESTED SAFETY

With the internationally acknowledged GS label of tested safety, we ensure that our products meet the quality and safety standards of the German Product Safety Act (in short ProdSG). The GS label provides you with valuable assistance in deciding which product to buy. You can rely on the quality and safety of our products.

« SÉCURITÉ CERTIFIÉE »

Le label GS, de réputation internationale, nous permet de garantir que nos produits sont conformes aux exigences en termes de qualité et de sécurité prescrites par la loi allemande sur la sécurité des produits [Produktsicherheitsgesetz, ProdSG]. Pour vous, le label GS est une aide précieuse à l'achat. Vous pouvez compter sur la qualité et la sécurité de nos produits.

MADE IN GERMANY



badea verbindet anerkannte Markenqualität mit mehr als 25 Jahren Erfahrung und einer verantwortungsvollen Planung, Gestaltung und Fertigung in Ostwestfalen-Lippe in Deutschland. Im Rittergut Haus Beck in Löhne präsentiert sich die Marke im Rahmen einer großzügigen Dauer- ausstellung für Fachhandelspartner und Interessierte.

MADE IN GERMANY

badea combines acknowledged brand quality with over 25 years of experience and responsible planning, design and production in Germany's Ostwestfalen-Lippe region. At Haus Beck manor in Löhne, the brand is presented in a spacious permanent exhibition for specialist retail partners and prospective customers.

MADE IN GERMANY

badea allie qualité éprouvée et savoir-faire depuis plus de 25 ans et s'engage pour une planification, un agencement et une fabrication responsables au cœur de la région Westphalie Est-Lippe (Allemagne). Dans le manoir Haus Beck, à Löhne, la marque se présente dans le cadre d'une grande exposition permanente s'adressant aux revendeurs et aux prospects.

Unser Herz schlägt für Mensch und Natur. Das können Sie an jedem unserer badea-Möbelstücke erkennen. Denn es trägt das bekannteste deutsche Umweltzeichen, den Blauen Engel. Dafür setzen wir ausschließlich auf Holzwerkstoffe aus nachhaltiger Forstwirtschaft und emissionsarme Lacke. Die Mehrheit unserer Lieferanten kommt aus unserer Region und wirtschaftet nach vergleichbaren Umweltstandards wie wir. Unsere Verwaltung setzt zur Papierersparnis auf digitalisierte Prozesse und die Logistik ist stets darum bemüht, den Fuhrpark und die Streckenplanung so klimaschonend wie möglich zu gestalten – u. a. mit einer LKW-Flotte nach der Euro 6-Norm, einer wachsenden Zahl an Hybridfahrzeugen und haus-eigenen E-Tankstellen.

SUSTAINABILITY PARTNERS

We live for mankind and Mother Nature. This is evident in every piece of our badea furniture. Because it carries Germany's best-known environmental label, the Blue Angel. To achieve this, we only use wood-based materials from sustainable forestry and low-emission lacquers. The majority of our suppliers come from our region and operate with environmental standards comparable to those of our own. Our administration department uses digitised

processes to save paper, and our logistics operation constantly makes every effort to plan our fleet of vehicles and delivery routes as climate-friendly as possible – including a fleet of lorries that meets the Euro 6 standard, a growing number of hybrid vehicles and our own in-house vehicle recharging points.

ENSEMBLE POUR LA DURABILITÉ

Notre cœur bat pour l'homme et la nature, comme vous pouvez le constater dans chacun de nos meubles badea. Car ils portent le label Blauer Engel [Ange bleu], le plus célèbre label environnemental allemand. C'est pourquoi nous utilisons exclusivement des bois issus de sylviculture durable et des vernis non polluants. La plupart de nos fournisseurs sont de notre région et appliquent des normes environnementales comparables aux nôtres. Afin d'économiser du papier, nos bureaux misent sur des processus numériques et la logistique veille sans cesse à organiser le parc automobile et la planification des livraisons dans un souci de respect de l'environnement, notamment avec des poids lourds classés selon la norme d'émission Euro 6, un nombre croissant de véhicules hybrides et nos bornes de recharge pour voitures électriques.

Gemeinsam NACHHALTIG

EMISSIONSKLASSE UND CARB2



Unsere Span- und MDF-Platten sind besonders emissionsarm. Wir halten die US-Vorgaben nach CARB2 und TSCA Title VI ein, die noch strenger sind als die Vorgaben in Europa.

EMISSION CLASS AND CARB2

Our chipboard and MDF boards are particularly low-emission. We meet the US requirements of CARB2 and TSCA Title 6, which are even stricter than the requirements in Europe.

CLASSEMENT AUX FORMALDÉHYDES ET CARB2

Nos panneaux de particules et MDF se distinguent par leurs vertus non polluantes. Nous respectons les spécifications américaines CARB2 et TSCA Title VI, encore plus strictes que la réglementation européenne.

PEFC



Unser Unternehmen ist PEFC-zertifiziert. Damit ist garantiert, dass die Rohstoffe für unsere Badmöbel ausschließlich aus nachhaltig bewirtschafteten Wäldern stammen.

PEFC

Our company is PEFC certified. This guarantees that the raw materials for our bathrooms only come from sustainably managed forests.

PEFC

Notre entreprise est certifiée PEFC. Le garant que le bois entrant dans la fabrication de nos salles de bains provient exclusivement de forêts gérées durablement.

BLAUER ENGEL



www.blauer-engel.de/uz38

badea trägt den Blauen Engel. Denn die Holzwerkstoffe stammen aus nachhaltiger Forstwirtschaft, werden emissionsarm produziert und weiterverarbeitet und sind gesundheitlich unbedenklich.

BLUE ANGEL

badea has been awarded the Blue Angel label. Because the wood-based materials come from sustainable forestry, are produced and processed with low emissions and are harmless to health.

« BLAUER ENGEL »

badea porte le label Blauer Engel. Car les bois utilisés proviennent de sylviculture durable, nos meubles sont fabriqués et façonnés de manière non polluante et sont absolument sans danger pour la santé.

EKO - PUNKT

EKO-PUNKT

IM AUFTRAG DER ZUKUNFT

Unsere Verpackungen werden vom EKO-Punkt Transportverpackungen & Co. KG dem Kreislauf des Dualen Systems zugeführt und die Materialien verantwortungsvoll wiederverwertet.

" EKO - PUNKT "

The Cologne-based Transportverpackungen & Co. KG channels our shipping packagings into Germany's ,Dual System' of waste management, with the materials recovered being recycled in a responsible manner.

« EKO - PUNKT »

Nos emballages sont collectés par l'entreprise Transportverpackungen & Co. KG et les matériaux recyclés sont réutilisés.

KLIMANEUTRALES UNTERNEHMEN



Die Geschäftsführung und das gesamte Team von badea setzen sich zum Ziel, für zukünftige Generationen eine intakte Umwelt zu erhalten. Deshalb leisten wir einen zuverlässigen Beitrag zum Klimaschutz.

CLIMATE-NEUTRAL BUSINESS

The management and the entire team at badea have set themselves the goal of preserving an intact environment for future generations. It is in this way that we make a reliable contribution to protecting our climate.

ENTREPRISE CLIMATIQUEMENT NEUTRE

La direction et toute l'équipe badea se sont fixés pour objectif de préserver l'environnement pour les générations futures. C'est pourquoi nous nous engageons pour le climat.

OASE DES Wohlbefindens

Ganz auf Ihre Ansprüche hin eingerichtet, avanciert das Bad zur Oase des Wohlbefindens. Hier dreht sich alles um Ihre Wünsche. Raffinierte Lichtideen setzen blendfreie Akzente. Mit serienmäßigen Vollauszügen behalten Sie alles im Blick. Ausstattungsdetails wie Rollschränke und Sitzbänke bieten jeden Komfort. Gestalten Sie einen Raum, der dazu einlädt, den Alltag hinter sich zu lassen. Willkommen in Ihrem „Home Spa“!

HAVEN OF WELL-BEING

Furnished entirely to meet your expectations, the bathroom becomes a haven of well-being. Here, everything is about what you really want. Clever lighting ideas make glare-free statements. Fully extending drawers that feature as standard always show you where everything is. Features such as roller shutters and bench seats add to the comfort. Design a room that invites you to cast everyday routine aside. Welcome to your „Home Spa“!

HAVRE DE PAIX

Entièrement aménagée pour répondre à vos souhaits, la salle de bains devient un lieu de prédilection et un havre de paix. Ici, tout tourne autour de vous. Les éclairages judicieux soulignent sans éblouir. Grâce aux coulissants à sortie totale en série, vous avez toujours tout sous les yeux. Les équipements, tels que les caissons roulants et les bancs, sont très pratiques. Aménagez une pièce qui vous invite au dépaysement. Bienvenue dans votre espace bien-être !

CLASSIC & VARIPRO

Vielfalt ist Programm: Unsere Classic-Serie umfasst Badmöbel, Waschtische und Zubehör in Markenqualität. In 38 Frontdekoren, mit sechs Griffleisten oder mit 24 Griffen plus TipOn für Planungen ohne Griffe. VariPro bietet Möbel und Waschtische nach Maß, die sich nahtlos einfügen lassen.

Variety is the key: our Classic series includes bathroom furniture, washstands and accessories in brand-name quality. In 38 front decors with six grip ledges or with 24 handles plus TipOn for handleless designs. VariPro gives you tailor-made furniture and washbasins for a seamless fit.

La variété est au programme : notre série Classic propose des vasques, des accessoires et des meubles de salles de bains exclusifs. Et 38 décors façade, avec 6 poignées profil ou avec 24 poignées TipOn pour les planifications sans poignée. VariPro propose des meubles et vasques sur-mesure parfaitement adaptés les uns aux autres.



PLUS

Sie haben schon einen Waschtisch? Dann empfehlen wir Ihnen die Waschtischunterschranke unseres Programmes Plus. Passend dazu können Sie alle Optionen des Classic-Programmes ausschöpfen und mit den Ergänzungsmöbeln und Zubehörartikeln Ihr Traumbad rund um Ihren eigenen Waschtisch planen.

Already have a washstand? In this case, we recommend the vanity units from our Plus range. Proving the perfect match, you can take full advantage of all the options featured in the Classic range and plan your dream bathroom around your own washstand - complementing it with any of the furniture and accessory items there are to choose from.

Vous avez déjà une vasque ? Si oui, nous vous recommandons nos meubles sous vasque Plus. Vous pouvez les combiner avec les éléments secondaires et les accessoires Classic pour créer la salle de bains dont vous rêvez depuis toujours.

01



PURE

Puristisch, grifflos, geradlinig: So präsentiert sich unsere Serie Pure mit insgesamt 38 Frontdekoren. Dazu gesellen sich neun Aufsatzwaschtische aus hochwertiger Keramik, eine Variante aus edlem Glas, sieben Möbelwaschtische aus Mineralguss und drei Möbelwaschtische aus Keramik.

Purist, handleless, sleek: this is the mark of our Pure range offering no fewer than 38 front decors to choose from. These are joined by nine top-mounted washbasins in high-quality ceramic, one option in classy glass, seven furniture washbasins crafted from cast mineral material and three furniture washbasins made of ceramic.

Notre série Pure sans poignée, qui se distingue par ses lignes épurées et élégantes, est disponible avec 38 décors façade, 9 vasques à poser en céramique exclusive, une finition en verre noble, 7 meubles pour vasques en fonte minérale et 3 meubles pour vasques en céramique.

02

04



VISIT

Die Serie Visit haben wir für schmale Gästewaschräume und kleine Bäder konzipiert. Zur Auswahl stehen Waschtische und Schränke mit reduzierter Tiefe – in 38 Frontdekoren, mit sechs Griffleisten oder mit 24 Griffen plus TipOn für grifflose Planungen.

We have designed the Visit series for narrow guest toilets and small bathrooms. There is a choice of washbasins and cabinets in reduced depths – in 38 front decors with six grip ledges or with 24 handles plus TipOn for handleless designs.

Nous avons conçu la série Visit pour les salles d'eau d'invités étroites et les petites salles de bains. Les vasques et meubles, disponibles avec un faible encombrement en profondeur, se déclinent en 38 décors façade, avec 6 poignées profil ou 24 poignées TipOn pour les planifications sans poignée.

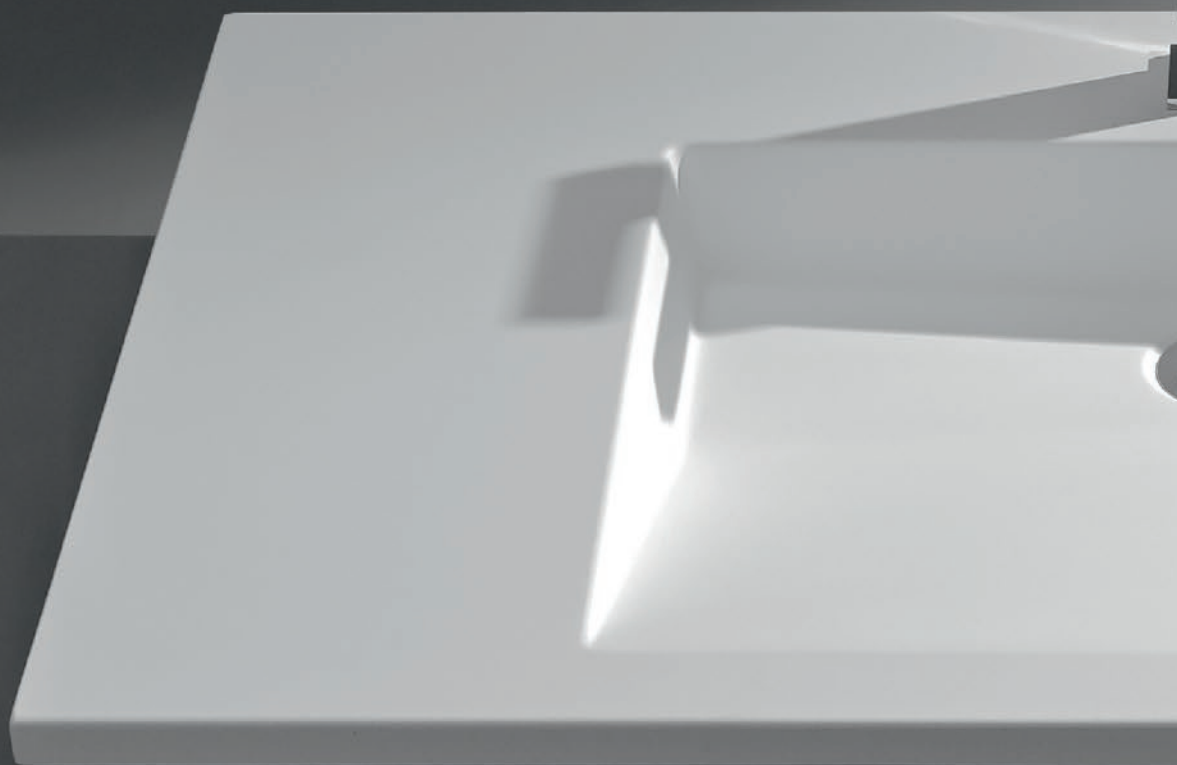

Futura 2
610, 810, 910, 1010, 1210 mm

Vielfalt trifft auf QUALITÄT UND SOLIDITÄT

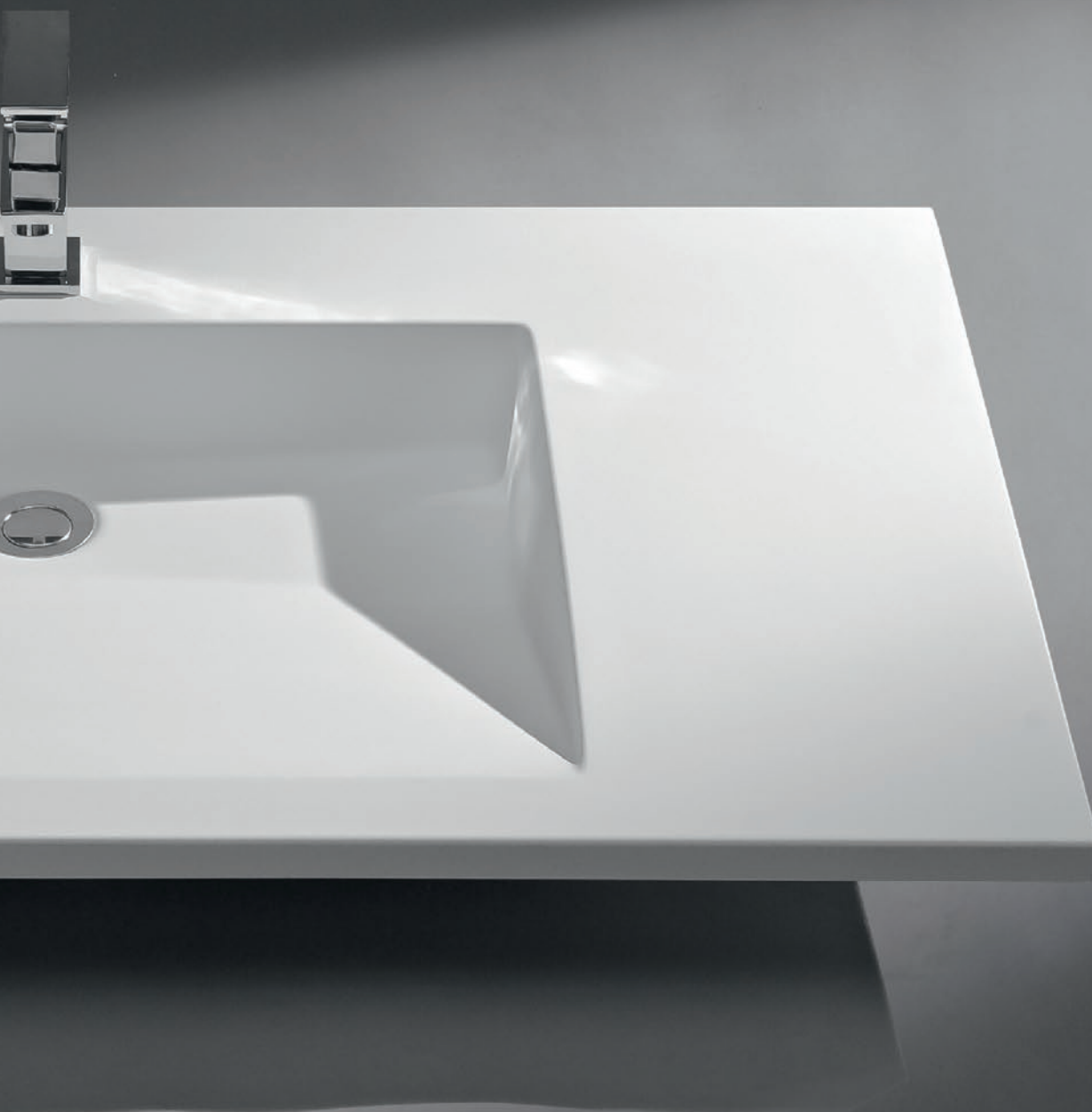

DIVERSITY MEETS QUALITY AND SOLIDITY
DIVERSITÉ, QUALITÉ ET EXCELLENCE RÉUNIES

WASCHTISCHUNTERSCHRÄNKE

CLASSIC, VARIPRO, PLUS & PURE WASHBASIN VANITY UNITS

MEUBLES SOUS VASQUE CLASSIC, VARIPRO, PLUS & PURE

Gestalten Sie Ihr persönliches Bad mit unserer umfangreichen Kollektion an Waschtischunterschrank. Individuell in passgenauen Höhen, Breiten und Tiefen geplant. So nimmt Ihre Wunschausstattung Gestalt an. Unser Programm **Classic** eröffnet Ihnen große Gestaltungsfreiheit, **VariPro** bietet Maßanfertigungen, z. B. für Nischen, und **Plus** harmonisiert perfekt mit Markenwaschtischen namhafter Hersteller. Unser Gestaltungstipp: Entdecken Sie passend zur Kollektion unsere Ergänzungsmöbel, die sich modular einplanen lassen und Ihnen ein Extraplus an Stauraum schenken.

WASHSTAND VANITY UNITS

*Design your very own personal bathroom with our extensive collection of washstand vanity units. Configured in precisely the right height, width and depth to suit any preference and situation. This is how to get the exactly style and feel you're looking for. Our **Classic** range gives you tremendous creative*

*flexibility, **VariPro** provides made-to-measure solutions, e.g. for alcoves, and **Plus** harmonises perfectly with washstands from prominent brand names. Our design tip: discover our furniture line-up to complement and match the collection - which can be planned on a modular basis to give you that extra portion of storage space.*

MEUBLES SOUS VASQUE

Créez votre salle de bains grâce à notre vaste collection de meubles sous vasque. Conçus sur-mesure en hauteur, en largeur et en profondeur. Pour que votre aménagement devienne réalité. **Classic** vous propose une grande liberté d'aménagement, **VariPro** permet de personnaliser les modèles, par ex. pour les crédences, et **Plus** s'harmonise parfaitement avec les vasques de célèbres fabricants. Notre conseil : découvrez les éléments secondaires modulaires, assortis à notre collection et optimisez votre rangement.

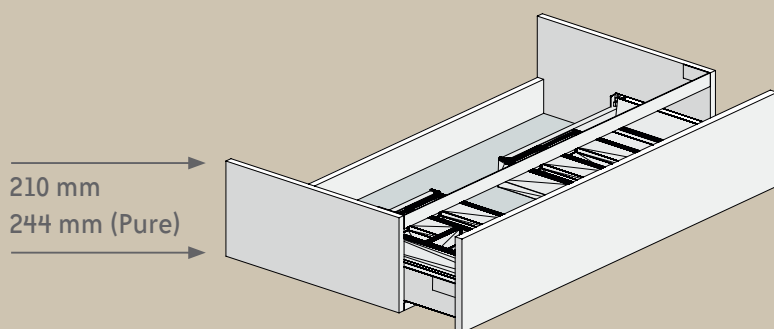

1 Auszug mit Siphonausschnitt
inkl. Kosmetikeinsatz im Auszug
Nicht lieferbar für Faro, Contour,
Linea, Max, Vegas, Eden, PLUS

—
1 pull-out with U-bend cut-out
including make-up insert in the pull-out
Not available for Faro, Contour, Linea,
Max, Vegas, Eden, PLUS

—
1 coulissant avec découpe du siphon
et insert pour produits de beauté
Non disponible pour Faro, Contour,
Linea, Max, Vegas, Eden, PLUS

1 Auszug ohne Siphonausschnitt
1 Innenauszug mit Siphonausschnitt
inkl. Kosmetikeinsatz im Innenauszug

—
1 pull-out without U-bend cut-out
1 internal pull-out with U-bend cut-out
including make-up insert in the internal pull-out

—
1 coulissant sans découpe du siphon
1 coulissant intérieur avec découpe du siphon et
insert pour produits de beauté

420 mm
454 mm (Pure)

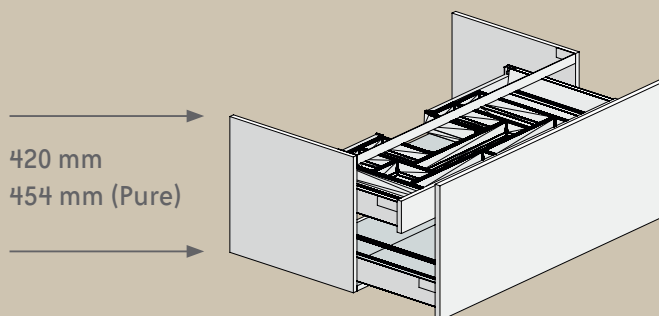

CLASSIC, VARIPRO, PLUS & PURE

- 1 Auszug ohne Siphonausschnitt
-
- 1 pull-out without U-bend cutout
-
- 1 coulissant sans découpe du siphon

420 mm
454 mm (Pure)

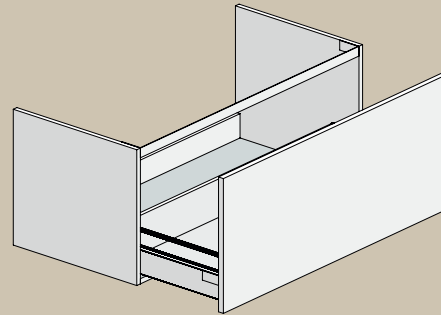

420 mm
486 mm (Pure)

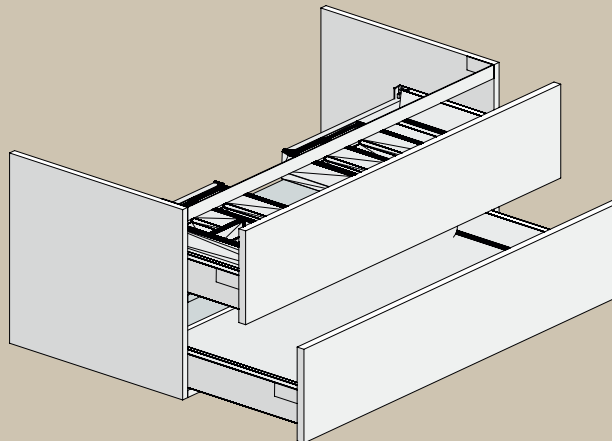

- 2 Auszüge
- oberer Auszug mit Siphonausschnitt
- inkl. Kosmetikeinsatz im oberen Auszug
-
- 2 pull-outs
- top pull-out with U-bend cut-out
- including make-up insert in the top pull-out
-
- 2 coulissants
- coulissant supérieur avec découpe du
- siphon et insert pour produits de beauté

- 2 Auszüge
- oberer Auszug mit Siphonausschnitt
- inkl. Kosmetikeinsatz im oberen Auszug
-
- 2 pull-outs
- top pull-out with U-bend cut-out
- including make-up insert in the top pull-out
-
- 2 coulissants
- coulissant supérieur avec découpe du
- siphon et insert pour produits de beauté

630 mm
696 mm (Pure)

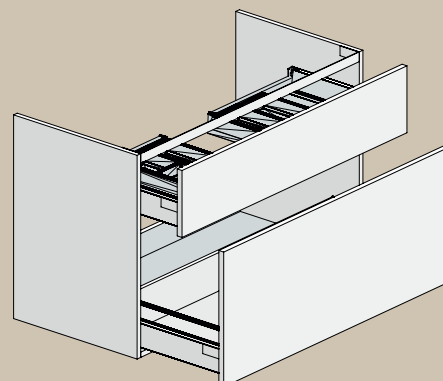

CLASSIC, PURE

Möbelwaschtische
Mineralguss
Furniture washbasins
mineral cast
Vasques fonte minérale
pour meubles



Forum

610, 810, 910,
1010, 1210 mm

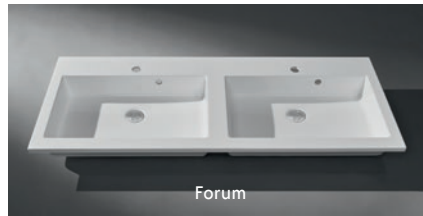

Forum

1210 mm



Futura 2

610, 810, 910,
1010, 1210 mm



Fidelio

910, 1210 mm



Fidelio

1210 mm



Contour

610, 810, 910,
1010, 1210 mm

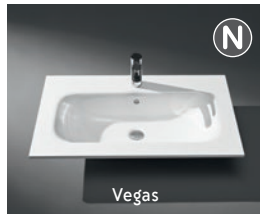

Vegas

605, 805, 905,
1005, 1205 mm



Vegas

1205 mm

CLASSIC, PURE

Möbelwaschtische
Keramik
Ceramic furniture
washbasins
Vasques céramique
pour meubles



Nordic

610, 810, 910,
1010, 1210 mm



Nordic

1210 mm



Square

604, 804, 910,
1004, 1204 mm

CLASSIC

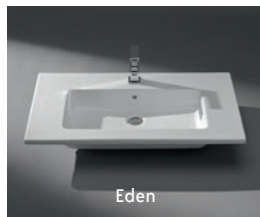

Eden

617, 822, 920,
1024, 1223 mm

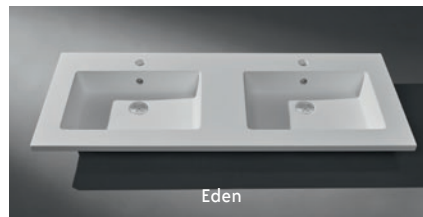

Eden

1222 mm



Modena

600 x 420 mm

CLASSIC, PURE

Keramikaufsatz-
waschtische
Ceramic countertop
washbasins
Vasques à poser
céramique



Como

○ 465 mm



Pisa

550 x 360 mm



Livorno

510 x 380 mm



Monza

370 mm

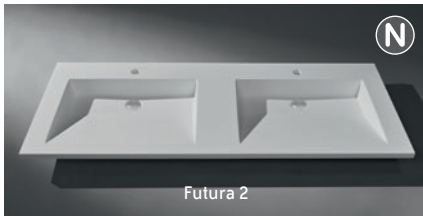

Futura 2

1210 mm



Faro

612, 812, 1012 mm

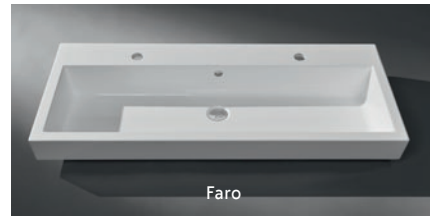

Faro

1012 mm

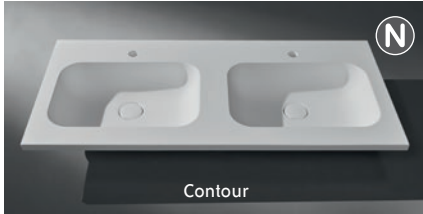

Contour

1210 mm



Max

605, 805, 905,
1005, 1205 mm



Max

1205 mm

CLASSIC

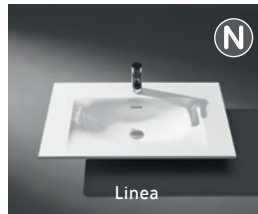

Linea

605, 805, 905,
1005, 1205 mm

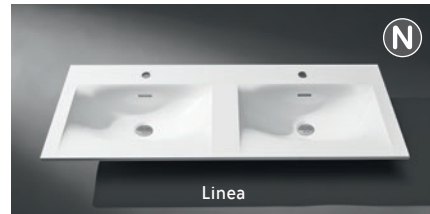

Linea

1205 mm



Square

1204 mm

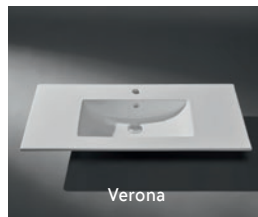

Verona

610, 810, 910,
1010, 1210 mm



Verona

1210 mm



Modena

600 x 420 mm



Imola

420 mm



Bari

○ 360 mm

CLASSIC, PURE

Keramikaufsatz-
waschtische & Glas-
aufsatzwaschtische
Ceramic countertop
washbasins and glass
countertop washstands
Vasques à poser
céramique & vasques
à poser verre



○ 360 mm



600 x 420 mm



600 x 420 mm



○ 390 mm

VARIPRO

Maßvariable Möbel-
waschtische Mineralguss
460 mm und 555 mm Tiefe
Variable in size furniture
washbasins mineral
cast, 460 mm and
555 mm deep
Vasques de meubles à
dimensions variables en
fonte minérale 460 mm
et 555 mm de profondeur

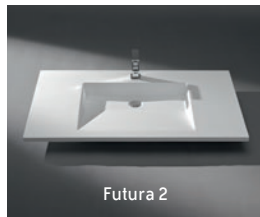

460 mm: 600-2400 mm
555 mm: 700-2400 mm

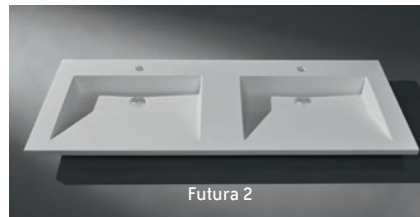

460 mm: 1200-2400 mm
555 mm: 1400-2400 mm

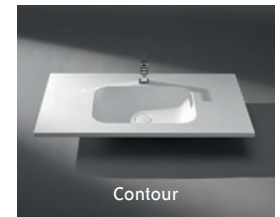

600-2400 mm



700-2400 mm

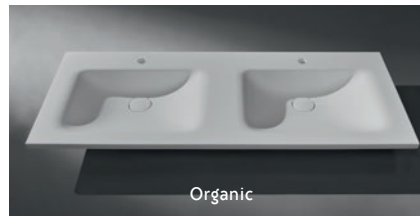

460 mm: 1300-2560 mm
555 mm: 1400-2400 mm



555 mm: 600-2400 mm

VARIPRO

Maßvariable Möbelwasch-
tische Glas 500 mm Tiefe
Variable in size furniture
washbasins glass
500 mm depth
Vasques de meubles à di-
mensions variables verre
500 mm de profondeur



612-1912 mm

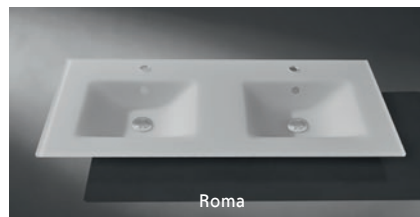

1212, 1412, 1612 mm

PG1
Verfügbar in:
Weiß glänzend,
Quarzgrau glänzend
Available in:
white glossy,
quartz grey glossy
Disponibles en :
blanc brillant,
gris quartz brillant

VISIT

Möbelwaschtische
Mineralguss
Furniture washbasins
mineral cast
Vasques fonte minérale
pour meubles



405, 505 mm



400 mm

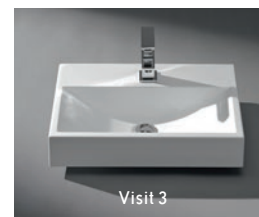

505 mm

VISIT

Keramikaufsatz-
waschtische &
Glasaufsatzwaschtische
Ceramic countertop
washbasins and
glasscountertop
washbasins
Vasques à poser
céramique & vasques
à poser verre

VISIT

Möbelwaschtische
Keramik
Ceramic furniture
washbasins
Vasques céramique
pour meubles



454 mm



454 mm

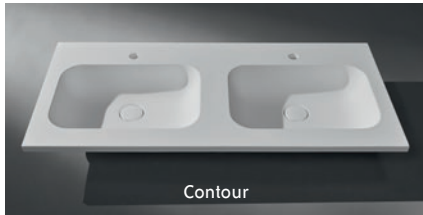

460 mm: 1200-3000 mm
555 mm: 1200-2400 mm



460 mm: 600-2400 mm

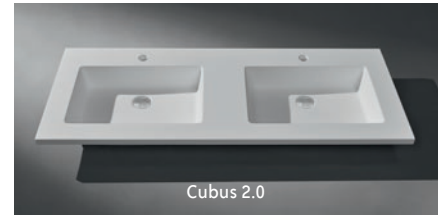

460 mm: 1200-3000 mm



555 mm: 1200-2400 mm

PG2

Verfügbar in:
Weiß matt,
Quarzgrau matt
Available in:
white matt,
quarz grey matt
Disponibles en :
blanc mat,
gris quartz mat

PG3

Verfügbar in:
Weiß stone,
Quarzgrau stone
Available in:
white stone,
quarz grey stone
Disponibles en :
blanc stone,
gris quartz stone



550 x 360 mm



510 x 380 mm



370 mm



○ 360 mm



○ 360 mm



○ 390 mm

Classic – MINERALGUSSWASCHTISCHE

CLASSIC – CAST MINERAL WASHBASINS
CLASSIC – VASQUES FONTE MINÉRALE



N

Max
605, 805, 905, 1005, 1205 mm



N

Futura 2
610, 810, 910, 1010, 1210 mm

Classic Mineralgusswaschtische sind mit und ohne Überlauf und Armaturlochbohrung verfügbar.
Classic cast mineral washbasins are available with and without overflow and mixer tap hole.
Les vasques fonte minérale Classic sont disponibles avec ou sans trop-plein et perçage robinetterie.









Waschtisch: Vegas
 Maße (B x T): 905 x 460 mm
 Front: 098 Weiß Hochglanz/
 018 Caramel
 Korpus: 143 Sandbeige matt
 Griff: 515/802 Schwarz matt
 Waschtischplatte: 841 Steinstruktur Patina

Washstand: Vegas
 Dimensions (W x D): 905 x 460 mm
 Front: 098 White High-gloss/
 018 Caramel
 Carcase: 143 Sand beige matt
 Handle: 515/802 Black matt
 Washstand top panel:
 841 Stone structure Patina

Vasque : Vegas
 Dimensions : 905 x 460 mm (l x p)
 Façade : 098 Blanc brillant/
 018 Caramel
 Corps : 143 Beige sable mat
 Poignée : 515/802 noir mat
 Plan de vasque :
 841 Structure minérale Patina





Alles in Ordnung: Schubkästen unter dem Waschtisch erleichtern den Zugriff auf allerhand Badutensilien. Sehenswert veredeln lässt sich der Waschmaschinenschrank mit einer hochwertigen 12 mm Waschtischplatte in Steinstruktur.



Everything neat and tidy: drawers under the washbasin provide easy access to all manner of bathroom utensils. The washing-machine unit can be given an eye-catching look with a high-quality 12 mm washbasin worktop in stone texture.



L'ordre règne : les tiroirs sous la vasque facilitent l'accès aux effets personnels. Un plan de vasque remarquable en structure minérale, 12 mm d'épaisseur, sublime le meuble lave-linge.

badea Badwelten
badea bathroom worlds
badea Salles de bains



Vollkommene Veredelung: Wenn dunkle Farben auf die Faszination von Messing und dunklen Hölzern treffen, erwacht ein intensiver, aber eleganter Look zum Leben.

Perfectly presented: when dark colours meet the fascination of brass and dark timbers, the result is an intense yet elegant look that comes to life.

L'élégance à la perfection : quand les couleurs chaudes côtoient le laiton fascinant et les bois foncés, on obtient un look intense et spectaculaire.





Harmony

Pure Gemütlichkeit: Warme, natürliche Farbtöne versprühen Geborgenheit. Naturmaterialien kombiniert mit Farben wie Sand, Greige und Caramel entspannen.

Truly inviting: warm, natural colour shades exude a homely feel. Natural materials combined with colours like as sand, greige and caramel are so relaxing.

L'ambiance conviviale et les teintes naturelles apportent l'harmonie. Les matériaux naturels, associés aux couleurs sable, grège et caramel, invitent à la détente.

Waschtisch: Contour
Maße (B): 1512 mm
Front: 276 Greige matt
Korpus: 127 Greige matt
Griffleiste: 253 Greige
—

Washstand: Contour
Dimensions (W): 1512 mm
Front: 276 Greige matt
Carcasse: 127 Greige matt
Grip ledge: 253 Greige
—

Vasque : Contour
Dimensions : 1512 mm (l)
Façade : 276 Greige mat
Corps : 127 Greige mat
Poignée profil : 253 Greige
—







badea Badwelten
badea bathroom worlds
badea Salles de bains

Ton in Ton: Die sanfte Farbe Greige zeigt sich ganzheitlich von ihrer harmonischen Seite. Besonderes Planungshighlight: der Waschtisch-unterschrank mit integriertem Stauraum für Ihre Waschmaschine.





CLASSIC



Tone in tone: the soft grège colour finish conjures a look of harmony wherever the eye turns. Cleverly planned highlight: the vanity unit with integrated space for fitting your washing machine.

Ton sur ton : la force du grège décent réside dans son harmonie holistique. Le meuble sous vasque permettant d'intégrer votre lave-linge attire tous les regards.

Classic –

KERAMIKWASCHTISCHE

CLASSIC – CERAMIC WASHBASINS

CLASSIC – VASQUES CÉRAMIQUES



Nordic
610, 810, 910, 1010, 1210 mm



S q u a r e
604, 804, 910, 1004, 1204 mm



V e r o n a
610, 810, 910, 1010, 1210 mm



M o d e n a
600 x 420 mm



M o d e n a
600 x 420 mm



E d e n
617, 822, 920, 1024, 1223 mm

Waschtisch: Eden
Maße (B x T): 1222 x 465 mm
LED-Aufsatzleuchte: Elba
LED-Unterbauleuchte: UL0112S
Front: 031 Quarzgrau matt
Korpus: 126 Quarzgrau matt
Griff: 263 Chrom

Washstand: Eden
Dimensions (W x D): 1222 x 465 mm
LED top-mounted light: Elba
LED built-under light: UL0112S
Front: 031 Quartz grey matt
Carcase: 126 Quartz grey matt
Handle: 263 Chrome

Vasque : Eden
Dimensions : 1222 x 465 mm (l x p)
Applique DEL : Elba
Luminaire DEL pour pose
sous éléments : UL0112S
Façade : 031 Gris quartz mat
Corps : 126 Gris quartz mat
Poignée : 263 Chrome

Hier kommen Körper und Geist zur Ruhe. Der Spiegelschrank unterstreicht die großzügige Raumwirkung mit ansprechender LED-Beleuchtung im offenen Fach.

Where body and soul can relax. The mirror cabinet emphasises the generous impression of space with attractive LED lighting in the open compartment.

Le corps et l'esprit trouvent ici leur plein épanouissement. L'armoire à glace souligne l'incroyable sensation d'espace grâce à un éclairage DEL attrayant dans le compartiment ouvert.





CLASSIC





CLASSIC



Waschtisch: Verona
 Maße (B x T): 1210 x 460 mm
 LED-Aufsatzleuchte: Capri
 LED-Unterbauleuchte: UL0190S
 Front: 234 Greige matt
 Korpus: 127 Greige matt
 Griff: 790 Messing gebürstet,
 997 TipOn
 —

Washstand: Verona
 Dimensions (W x D): 1210 x 460 mm
 LED top-mounted light: Capri
 LED built-under light: UL0190S
 Front: 234 Greige matt
 Carcase: 127 Greige matt
 Handle: 790 Brass, brushed,
 997 TipOn
 —

Vasque : Verona
 Dimensions : 1210 x 460 mm (l x p)
 Applique DEL : Capri
 Luminaire DEL pour pose
 sous éléments : UL0190S
 Façade : 234 Greige mat
 Corps : 127 Greige mat
 Poignée : 790 Laiton brossé,
 997 TipOn
 —



Raffiniert: Das LED-Lichtsegel **Capri** lässt sich dank **LightMotion** stufenlos dimmen. Ein Bewegungssensor steuert das Licht unter dem Waschtisch. Nachts garantiert es blendfreie Trittsicherheit.

*Clever touch: the **Capri** LED light sail can be dimmed to any chosen level with **LightMotion**. A motion sensor controls the light underneath the washstand vanity unit. At night, it guarantees glare-free sure footedness.*

Sophistiqué : **LightMotion** permet de régler en continu l'intensité lumineuse de l'applique DEL **Capri**. Un capteur de mouvement commande la lumière sous la vasque. Elle orientera dans le noir sans éblouir.





Waschtisch: Nordic
 Maße (B x T): 1210 x 460 mm
 LED-Aufsatzleuchte: Sicilia
 Front: 028 Dartmoor
 Korpus: 167 Dartmoor
 Griff: 797 chrom

—
 Washstand: Nordic
 Dimensions (W x D): 1210 x 460 mm
 LED top-mounted light: Sicilia
 Front: 028 Dartmoor
 Carcase: 167 Dartmoor
 Handle: 797 Chrome

—
 Vasque : Nordic
 Dimensions : 1210 x 460 mm (l x p)
 Applique DEL : Sicilia
 Façade : 028 Dartmoor
 Corps : 167 Dartmoor
 Poignée : 797 chrome



Flüsterleiser Komfort: Die vier geräumigen Auszüge unter dem Doppelwaschtisch schaffen Platz und schließen sich dank **Blumotion** sanft und kaum hörbar.

*Whisper-quiet practical convenience: the four spacious pull-outs below the double washstand provide storage and gently close in virtual silence thanks to **Blumotion**.*

Les quatre grands coulissants sous la vasque double, très pratiques, s'ouvrent et se ferment en douceur et en silence grâce à **Blumotion**.



Classic –

KERAMIKAUFSATZWASCHTISCHE

CLASSIC – CERAMIC COUNTERTOP WASHBASINS

CLASSIC – VASQUES À POSER EN CÉRAMIQUE



Pisa
550 x 360 mm



Livorno
510 x 380 mm



Monza
370 mm



Imola
420 mm



Modena
600 x 420 mm



Modena
600 x 420 mm



Como
Ø 465 mm



Bari
Ø 360 mm



Bari
Ø 360 mm





Waschtisch: Modena
 Maße (B x T x H): 600 x 420 x 132 mm
 Front: 031 Quarzgrau matt
 Korpus: 126 Quarzgrau matt
 Griffleiste: 254 Quarzgrau
 Waschtischplatte: 969 Marmor Grigio

Washstand: Modena
 Dimensions (W x D x H): 600 x 420 x 132 mm
 Front: 031 Quartz grey matt
 Carcase: 126 Quartz grey matt
 Grip ledge: 254 Quartz grey
 Washstand top panel: 969 Marmor Grigio

Vasque : Modena
 Dimensions : 600 x 420 x 132 mm (l x p x h)
 Façade : 031 Gris quartz mat
 Corps : 126 Gris quartz mat
 Poignée profil : 254 Gris quartz
 Plan de vasque : 969 Marmor Grigio

CLASSIC



Passt wie angegossen: Quarzgraue Metallregale bieten schönen Platz für hohe und niedrige Kunststoffboxen – inklusive verschiedener Deckel.

Perfectly matched: quartz-grey metal shelves provide a lovely place for high and low-rise plastic boxes – including various lids.

Les étagères métalliques gris quartz s'harmonisent merveilleusement avec les boîtes en plastique hautes et basses, ainsi que les différents couvercles.



Saubere **SACHE**

DER ANTI-FINGERPRINT-EFFEKT



IMMACULATE - THE ANTI-FINGERPRINT EFFECT
HYGIÈNE GARANTIE - LE REVÊTEMENT ANTI-TRACES DE DOIGTS



ANTI-FINGERPRINT-EFFEKT

Die neue Matrixlack-Front aus PG 4 ist dank strapazierfähigem und kratzfestem Material ein zuverlässiger Begleiter im Alltag. Fingerabdrücke, Flüssigkeiten und Co. prallen einfach ab, während ihre Farbe jahrelang zuverlässig bleibt. In puncto Stabilität und Funktionalität hat das innovative Material der neuen matten Glaslaminat-Fronten aus PG 5 ebenfalls viele Vorteile: Es ist im Vergleich zu Echtglas zehnmals bruchfester und 50 Prozent leichter. Gleichzeitig überzeugen die Oberflächen mit ihrer hohen Kratzbeständigkeit und einem geringen Pflegeaufwand.

Benefiting from its hard-wearing and scratchproof material, the new Matrix lacquer front from PG 4 is a reliable everyday companion. Finger marks, liquids and the like simply bounce off while its colour remains true for years on end. In terms of stability and functionality, the innovative material of the new matt glass laminate fronts from PG 5 also comes with a host of benefits: it is ten times more unbreakable and 50 per cent lighter than real glass. At the same time, the surfaces leave no margin of doubt with their high scratch resistance and need for very little maintenance.

La nouvelle façade laque Matrix, GP 4, qui se distingue par sa robustesse et sa résistance aux rayures, est idéale au quotidien. Les traces de doigts ni les liquides ne peuvent adhérer tandis qu'elle gardera son éclat comme au premier jour. En termes de stabilité et de fonctionnalité, la nouvelle façade en verre stratifié mat, GP 5, est imbattable : ce matériau innovant est dix fois plus résistant et pèse deux fois moins que le verre véritable. Par ailleurs, les surfaces, très résistantes aux rayures, sont faciles d'entretien.

PG 4



275
Weiß matt
White matt
Blanc mat



276
Greige matt/mat



277
Quarzgrau matt
Quartz grey matt
Gris quartz mat



279
Schwarz matt
Black matt
Noir mat



281
Sandbeige matt
Sand beige matt
Beige sable mat

PG 5



288
Carbon matt/mat



572
Sabbia matt/mat



574
Piano matt/mat



575
Aureo matt/mat

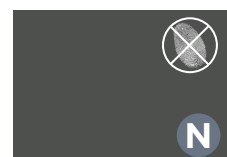

576
Titanio matt/mat



Filigraner Look, samtweiche Haptik: Mit nur 25 Millimetern Stärke verbreiten Waschtischplatte, Wandregale und der Rollschrank im Farbton Greige pure Wohlfühlatmosfera.

Delicate look, velvety soft feel: in a thickness of only 25 millimetres, the washbasin top, wall shelves and mobile unit in greige conjure a feel-good ambience par excellence.

Look en filigrane et agréable au toucher : de seulement 25 mm d'épaisseur, le plan de vasque, les étagères murales et le caisson roulant en grège apportent une sensation de bien-être à la salle de bains.



Waschtisch: Pisa

Maße (B x T x H): 550 x 360 x 120 mm

Front: 234 Greige matt

Korpus: 127 Greige matt

Griff: 997 TipOn

Waschtischplatte: 979 Sand

—

Washstand: Pisa

Dimensions (W x D x H): 550 x 360 x 120 mm

Front: 234 Greige matt

Carcase: 127 Greige matt

Handle: 997 TipOn

Washstand top panel: 979 Sand

—

Vasque: Pisa

Dimensions : 550 x 360 x 120 mm (l x p x h)

Façade : 234 Greige mat

Corps : 127 Greige mat

Poignée : 997 TipOn

Plan de vasque : 979 Sand

—

CONVENIENCE
UNBOUNDED
CONFORT ILLIMITÉ



KOMFORT ohne Grenzen

Waschtisch: Bari
Maße: Ø 360 mm
LED-Aufsatzleuchte: Capri
Front: 252 Black green
Korpus: 117 Carbon matt
Griff: 997 TipOn

—
Washstand: Bari
Dimensions: Ø 360 mm
LED top-mounted light: Capri
Front: 252 Black green
Carcase: 117 Carbon matt
Handle: 997 TipOn

—
Vasque : Bari
Dimensions : Ø 360 mm
Applique DEL : Capri
Façade : 252 Black green
Corps : 117 Carbon mat
Poignée : 997 TipOn



CLASSIC





Ein Bad, offen für alle: Barrierefreiheit schafft Wohlmomente und garantiert volle Funktionalität. Die Stützkonsole, Siphon und Armatur versprühen einen industriell-urbanen Touch.



CLASSIC



A bathroom open to everyone: barrier-free accessibility creates feel-good moments and guarantees unbridled functionality. The support brackets, U-bend and mixer tap exude an industrial, urban touch.

Une salle de bains accessible à tous invite à passer d'agréables moments et garantit le maximum de fonctionnalité. Le siphon, la robinetterie et la console de support affirment leur caractère urbain industriel.



Aufgeräumter Charakter: Im offenen Fach ist das Wichtigste griffbereit.
Der Auszug darunter sorgt diskret für Ordnung.

Tidy by nature: the open compartment keeps the most important things in easy reach. The pull-out below provides understated order.

Tous les accessoires importants sont toujours à portée de main dans le compartiment ouvert. Le coulissant inférieur optimise le rangement avec discrétion.



Waschtisch: Livorno
 Maße (B x T x H): 510 x 380 x 120 mm
 Front: 234 Greige matt
 Korpus: 127 Greige matt
 Griffleiste: 243 schwarz matt
 Waschtischplatte: 961 Skyfall

—
 Washstand: Livorno
 Dimension (W x D x H): 510 x 380 x 120 mm
 Front: 234 Greige matt
 Carcase: 127 Greige matt
 Grip ledge: 243 Black matt
 Washstand top panel: 961 Skyfall

—
 Vasque : Livorno
 Dimensions : 510 x 380 x 120 mm (l x p x h)
 Façade : 234 Grège mat
 Corps : 127 Grège mat
 Poignée profil : 243 noire mat
 Plan de vasque : 961 Skyfall



Nah an der Natur: Dank strukturierter Fronten im Holzdekor kommt wohlige Stimmung auf.

Close to nature: textured fronts in wood decor convey a feel-good mood.

Les façades structurées décor bois, qui rappelle la nature, créent une ambiance chaleureuse.



Mit der **TipOn**-Funktion öffnet sich der Auszug und präsentiert sein Innenleben im Farbton Quarzgrau.

*The pull-out opens with **TipOn** function, presenting its interior in the quartz grey colour shade.*

La fonction **TipOn** permet d'ouvrir le coulissant qui dévoile son organisation intérieure en gris quartz, notre coloris.



Waschtisch: Pisa
 Maße (B x T x H): 550 x 360 x 120 mm
 Front: 070 Grain hell
 Korpus: 196 Grain hell
 Griff: 997 TipOn
 Waschtischplatte: 882 Grain hell

—
 Washstand: Pisa
 Dimensions (W x D x H): 550 x 360 x 120 mm
 Front: 070 Grain light
 Carcase: 196 Grain light
 Handle: 997 TipOn
 Washstand top panel: 882 Grain light

—
 Vasque : Pisa
 Dimensions : 550 x 360 x 120 mm (l x p x h)
 Façade : 070 Grain clair
 Corps : 196 Grain clair
 Poignée : 997 TipOn
 Plan de vasque : 882 Grain clair



Waschtisch: Modena
 Maße (B x T x H): 600 x 420 x 132 mm
 Front: 205 Ulme gekälkt
 Korpus: 155 Ulme gekälkt
 Griff: 263 chrom
 Waschtischplatte: 952 Ulme gekälkt

Washstand: Modena
 Dimensions (W x D x H): 600 x 420 x 132 mm
 Front: 205 Elm, limed
 Carcase: 155 Elm, limed
 Handle: 263 Chrome
 Washstand top panel: 952 Elm, limed

Vasque : Modena
 Dimensions : 600 x 420 x 132 mm (l x p x h)
 Façade : 205 Orme blanchi
 Corps : 155 Orme blanchi
 Poignée : 263 Chrome
 Plan de vasque : 952 Orme blanchi

Großzügig geplant: Gut sortiert kommt vieles im Waschtischunterschrank unter Dach und Fach. Das schlanke Highboard sorgt trotz geringer Tiefe für noch mehr Platz.
 Tipp: Stauraum hat man definitiv nie genug.

*Spaciously planned: all sorts of items find a well-organised home in the washstand vanity unit. Despite its shallow depth, the slim-line highboard provides even more space.
 Tip: you definitely never have enough storage space.*

Planification généreuse : tout est parfaitement rangé dans le meuble sous vasque. Certes étroit mais moins profond, le buffet haut offre encore plus de place. Astuce : on n'a jamais assez de place.





Pure – GRIFFLOSES BAD

PURE – HANDLELESS BATHROOM
PURE – SALLE DE BAINS SANS POIGNÉE

Ruhe und Reinheit bestimmen wohlige Rückzugsorte. Badezimmer avancieren mit dem badea Pure Programm zur Wohlfühloase: Ein geradliniges, minimalistisches Design bei griffloser Planung konzentriert sich auf das Wesentliche und lenkt nicht ab. Die Griffprofile sind auch in beleuchteter Variante planbar – für ein ebenso modernes wie zeitloses Raumgefühl, das sich entspannt genießen lässt.

Peace and purity define comforting havens of bliss. The badea Pure range makes bathrooms a sanctuary of well-being: configured without handles, sleek, minimalist design focuses on the essentials, leaving nothing to distract. The finger pulls can also be planned with illumination – for a modern yet timeless feeling of space to find and enjoy moments of relaxation.

Une salle de bains douillette se distingue par le calme et la pureté. Grâce au programme badea Pure, elle se transforme en havre de paix: une planification sans poignée au design épuré et minimaliste se concentre sur l'essentiel sans détourner l'attention. Les poignées en creux peuvent être également éclairées pour créer une pièce moderne et intemporelle placée sous le signe de la détente.

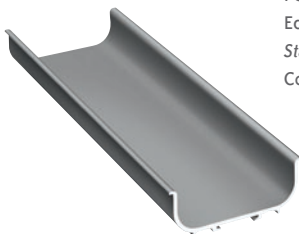

FG 399
Edelstahlfarbig
Stainless steel coloured
Couleur inox



FG 456
Schwarz gepulvert
Black, powder-coated
Noir, poudre époxy



FG 420
Weiß gepulvert
White, powder-coated
Blanc, poudre époxy



FG 422
Quarzgrau gepulvert
Quartz grey, powder-coated
Gris quartz, poudre époxy



Pure Schönheit: Unsere grifflose Serie **Pure** setzt auf eine reduzierte Linienführung und elegante Zurückhaltung. Das Ergebnis ist eine architektonisch überzeugende Designqualität, die über viele Jahre ihre Gültigkeit behält.



Waschtisch: Livorno
Maße (B x T x H): 510 x 380 x 120 mm
Front: 276 Greiße matt
Korpus: 127 Greiße matt
Griffprofil: FG 456 Schwarz gepulvert
Waschtischplatte: 962 Mocca

—
Washstand: Livorno
Dimensions (W x D x H): 510 x 380 x 120 mm
Front: 276 Greiße matt
Carcasse: 127 Greiße matt
Handle: FG 456 Black, powder-coated
Washstand top panel: 962 Mocca

—
Vasque : Livorno
Dimensions : 510 x 380 x 120 mm (l x p x h)
Façade : 276 Greiße mat
Corps : 127 Greiße mat
Poignée : FG 456 Noir, poudre époxy
Plan de vasque : 962 Mocca

*Pure beauty: our handleless **Pure** range is based on reduced lines and elegant understatement. The result is an architecturally irresistible design quality that will retain its validity for many years.*

Une pure beauté : notre série **Pure** sans poignée se distingue par ses lignes minimalistes et son élégance sobre. Le résultat : un design d'une qualité exceptionnelle, prévu pour durer de très nombreuses années.

badea Badwelten
badea bathroom worlds
badea Salles de bains





badea Badwelten
badea bathroom worlds
badea Salles de bains



Waschtisch: Bari
Maße: Ø 360 mm
Front: 155 Kito Stahl
Korpus: 521 Kito Stahl
Griffprofil: FG 399 Edelstahlfarbig
Waschtischplatte: 960 Kito Stahl

—
Washstand: Bari
Dimensions: Ø 360 mm
Front: 155 Kito steel
Carcase: 521 Kito steel
Handle: FG 399 Stainless steel coloured
Washstand top panel: 960 Kito steel

—
Vasque : Bari
Dimensions : Ø 360 mm
Façade : 155 Kito acier
Corps : 521 Kito acier
Poignée : FG 399 Couleur inox
Plan de vasque : 960 Kito acier



Blickfang: Die Griffprofile gibt es wahlweise in Weiß, Schwarz, Quarzgrau und Edelstahlfarbig – auf Wunsch auch mit effektvoller Beleuchtung.

Eye-catcher: the handle profiles are available in white, black, quartz grey and stainless steel colour – on request, also with attractive lighting.

Disponibles en blanc, noir, gris quartz et couleur inox, les poignées profilées attirent tous les regards et peuvent être, sur demande, équipées d'un éclairage ambiance.

Industrial Design:
Selbstbewusst und
stilsicher wirken rusti-
kale, derbe Fronten –
vor allem, wenn sie von
prägnanten Griffen und
dunklen Hölzern unter-
stützt werden.

*Industrial design: rustic,
rugged fronts leave an
impression of confidence
and style – particularly
when they come with
striking handles and
dark timber finishes.*

Industrial Design :
les façades rustiques
misent résolument sur
le style, notamment si
elles sont soulignées
par des poignées
marquantes et des
bois foncés.



Herrlich lebendig: Zwischen frischen Pflanzen und metallischen Accessoires präsentieren sich frische, junge Farbtöne besonders gern.

Wonderfully vibrant: refreshing, young colour shades cut a particularly good figure amid verdant plants and metallic accessories.

La joie de vivre : les teintes jeunes et fraîches aiment côtoyer les plantes vertes et les accessoires métalliques.

playful







Waschtisch: Bari
 Maße: Ø 360 mm
 Front: 158 Sand
 Korpus: 527 Sand
 Griffprofil: FG 456 Schwarz gepulvert
 Waschtischplatte: 979 Sand

—
 Washstand: Bari
 Dimension: Ø 360 mm
 Front: 158 Sand
 Carcase: 527 Sand
 Handle: FG 456 Black, powder-coated
 Washstand top panel: 979 Sand

—
 Vasque : Bari
 Dimensions : Ø 360 mm
 Façade : 158 Sand
 Corps : 527 Sand
 Poignée : FG 456 Noir, poudre époxy
 Plan de vasque : 979 Sand



PURE



badea Badwelten
 badea bathroom worlds
 badea Salles de bains



LICHTKONZEPT individuell gestaltet

Licht setzt in Szene, leuchtet aus, wo es wichtig ist und bietet zu jeder Tageszeit Orientierung. Unsere **LightMotion**-Leuchten lassen sich individuell an- und abschalten, auf Wunsch dimmen und stufenlos von Warm- zu Kaltweiß regulieren. Sie haben die Wahl: Wir bieten Ihnen Beleuchtungskomfort ganz nach Wunsch und Maß.

INDIVIDUALLY TAILORED LIGHTING CONCEPT

*Lighting sets the scene, provides illumination where it's important and offers orientation at any time of the day. Our **LightMotion** luminaires can be switched on and off to suit any individual preference, dimmed if chosen and continuously varied from warm to cool white. The choice is yours: we can give you made-to-measure lighting convenience of any type you choose.*

ÉCLAIRAGE À AMÉNAGER INDIVIDUELLEMENT

La lumière met en valeur, éclaire là où il le faut et permet de s'orienter à toute heure de la journée. Il est possible d'allumer et d'éteindre individuellement nos lampes **LightMotion**, de varier leur intensité lumineuse et la température de couleur, réglée en continu de blanc chaud à blanc froid, en fonction des envies personnelles. Vous avez le choix : nous vous proposons un confort d'éclairage pour répondre à toutes vos attentes.





Hier geht das Licht auf: Die richtige Beleuchtung sorgt für ein stimmungsvolles Ambiente – außen an Badspiegel und filigranen Griffprofilen, innen für Schubkästen und Auszüge. Einfach strahlend schön!

This calls for light: the right illumination creates an atmospheric mood – outside on the bathroom mirror and delicate grip ledges, inside for drawers and pull-outs. Radiant appeal no finer!

Place à la lumière ! Le bon éclairage crée une ambiance chaleureuse : dehors, sur le miroir et sur les poignées profil en filigrane, dedans, dans les tiroirs et coulissants. Remarquable !



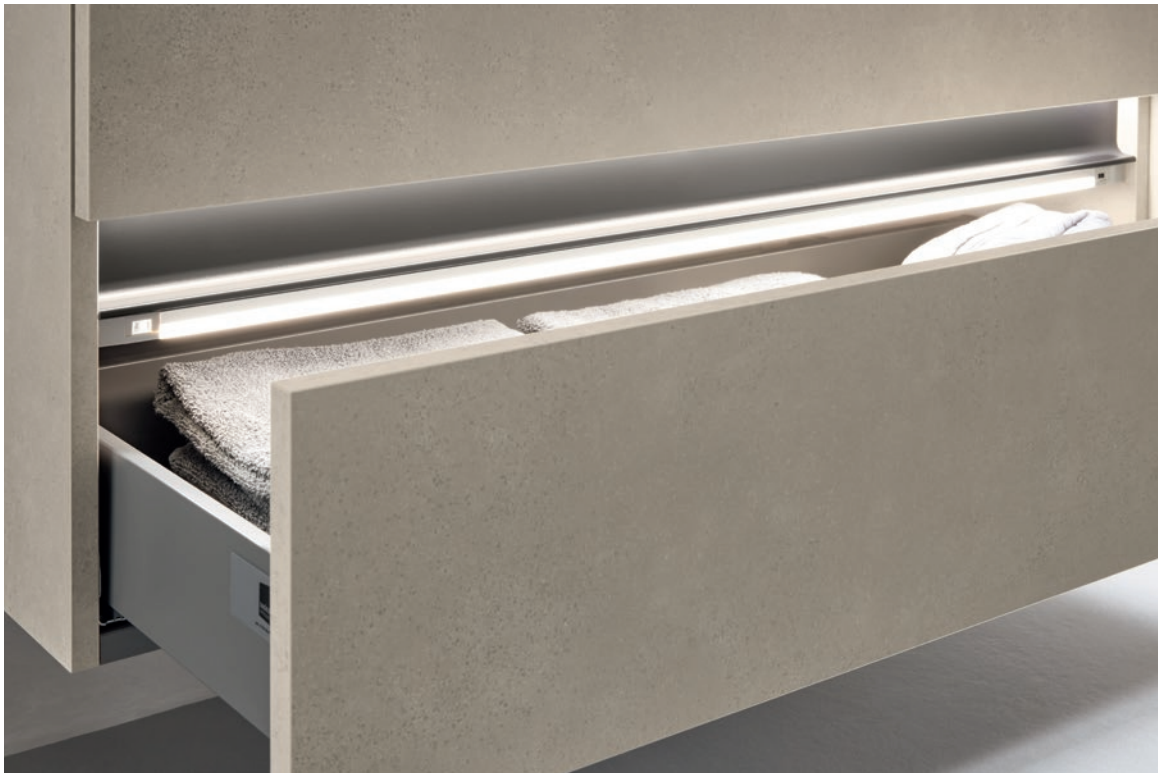

PURE



Futura 2
460 mm: 600-2400 mm
555 mm: 700-2400 mm



Contour
600-2400 mm



Organic
700-2400 mm



Organic 2.0
555 mm: 1200 - 2400 mm

VariPro –

MASSVARIABLE

MINERALGUSSWASCHTISCHE

VARI PRO – VARIABLE-SIZE CAST MINERAL WASHBASINS

VARI PRO – VASQUES FONTE MINÉRALE À DIMENSIONS VARIABLES



Cubus 2.0
460 mm: 1200 - 3000 mm

VARI PRO



Waschtisch: Cubus 2.0
 Maße (B x T): 1212 x 460 mm
 Front: 084 Wild Oak
 Korpus: 160 Schwarz matt
 Griff: 226 Schwarz gepulvert
 —
 Washstand: Cubus 2.0
 Dimensions (W x D): 1212 x 460 mm
 Front: 084 Wild Oak
 Carcase: 160 Black matt
 Handle: 226 Black, powder-coated
 —
 Vasque : Cubus 2.0
 Dimensions : 1212 x 460 mm (l x p)
 Façade : 084 Wild Oak
 Corps : 160 Noir mat
 Poignée : 226 Noir, poudre époxy
 —

Jeder Raum ist anders und erfordert in puncto Badmöblierung eine Planung nach Maß. Unser Programm **VariPro** gibt auf Einrichtungsfragen die passende Antwort: Das variable Waschtischsystem ist auf den Zentimeter genau planbar. Der Clou: Bei der Waschmulde konnten wir dank eines innovativen Siphonsystems auf ein Überlaufloch verzichten. Das erlaubt besonders designorientierte Planungen. Sie haben die Wahl: Das Waschtischsystem ist mit und ohne Hahnloch bestellbar und in Weiß Glanz oder matt lieferbar.

*Every space is different and calls for customised planning when it comes to furnishing a bathroom. Our **VariPro** range has the right answer to any furnishing question: the versatile washstand system can be configured to optimise every last inch of space. The clever part: thanks to an innovative U-bend system, we have been able to omit an overflow hole in the basin. This makes way for planning bathrooms with a particular focus on exquisite design. The choice is yours: the washstand system can be ordered with or without tap hole and is available in gloss or matt white.*

Aucune salle de bains ne se ressemblant, elle demande donc une planification sur mesure en termes d'ameublement. À la question de savoir comment, notre programme **VariPro** répond : la vasque à dimensions variables permet d'aménager au centimètre près. Le clou : grâce à un siphon innovant, la vasque peut se passer du trop-plein, ce qui permet de réaliser les idées résolument design. Vous pouvez choisir la vasque avec ou sans perçage robinetterie, en blanc brillant ou mat.

VARI PRO

VariPro bietet Möbel und Waschtische nach Maß, die sich nahtlos einfügen lassen.

VariPro gives you tailor-made furniture and washstands for a seamless fit.

VariPro propose des meubles et vasques sur-mesure parfaitement adaptés les uns aux autres.

5 BECKENFORMEN

5 BASIN DESIGNS

5 BACS

FUTURA 2

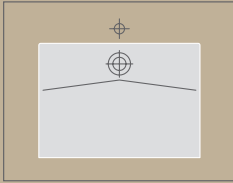

CONTOUR



ORGANIC

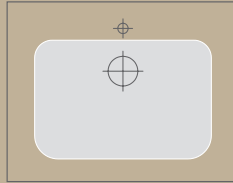

ORGANIC 2.0

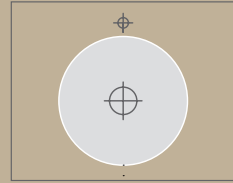

CUBUS 2.0

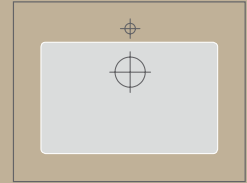

ANZAHL AN WASCHTISCHEN

NUMBER OF WASHBASINS

NOMBRE DE VASQUES

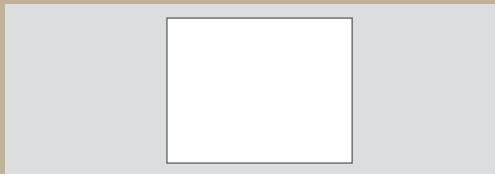

Einzelwaschtisch
Single washstand
Vasque simple

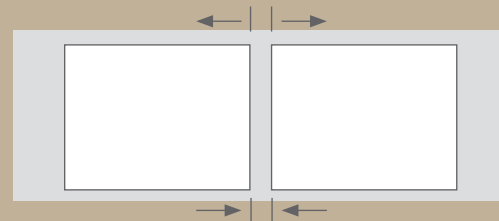

Doppelwaschtisch
Double washstand
Vasque double

VARIABLE BREITEN UND BECKENPOSITIONEN

VARIABLE WIDTHS AND WASHSTAND POSITIONS

PLUSIEURS LARGEURS ET POSITIONS DU BAC

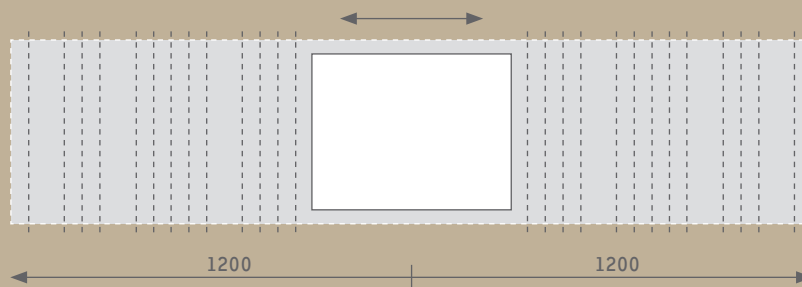

Es stehen zwei Tiefenmaße zur Auswahl: 555 mm und 460 mm. Die Breitenmaße variieren je nach Waschtischmodell. Fragen Sie am besten Ihren Badspezialisten. Er berät Sie gern.

There are two depths to choose from: 555 mm and 460 mm. Widths vary depending on washstand model.

It is best to ask your bathroom specialist. He or she will be pleased to advise you.

Deux profondeurs au choix: 555 et 460 mm, les largeurs varient selon la vasque. N'hésitez pas à contacter votre spécialiste salle de bains qui se tient à votre entière disposition.



VARI PRO SELBST GEPLANT
PLANNING VARI PRO YOURSELF
VARI PRO AMÉNAGÉ SOI-MÊME



Waschtisch: Organic 2.0
Maße (B x T): 1912 x 555 mm
Front: 011 Weiß matt/
251 Black blue
Korpus: 516 Weiß matt
Griff: 997 TipOn

—
Washstand: Organic 2.0
Dimensions (W x D): 1912 x 555 mm
Front: 011 White matt/
251 Black blue
Carcase: 516 White matt
Handle: 997 TipOn

—
Vasque : Organic 2.0
Dimensions : 1912 x 555 mm (l x p)
Façade : 011 Blanc mat/
251 Black blue
Corps : 516 Blanc mat
Poignée : 997 TipOn



Anspruchsvolle Lösung: Lückenlos fügt sich der maßvariable Designwaschtisch **Organic 2.0** in die Nische ein.

*Exacting solution: variable in size, the **Organic 2.0** designer washstand fits seamlessly into the space available.*

Solution exigeante : la vasque design **Organic 2.0**, à dimensions variables, s'intègre parfaitement dans la niche.





VARI PRO



Entspannen bei warmer, weicher Beleuchtung oder Schminken bei Tageslichthelligkeit – unser LED-Flächenspiegel **Flat** rückt alles ins rechte Licht. Auf Knopfdruck, stufenlos regel- und dimmbar.

*Relaxing in warm, soft lighting or putting on make-up in day-bright light – our **Flat** LED wall mirror puts everything in the right light. Infinitely variable and dimmable at the press of a button.*

Un éclairage chaud et doux pour se détendre ou une lumière diurne pour se maquiller – notre miroir DEL **Flat** met tout en valeur. Il suffit d'appuyer sur un bouton pour régler en continu l'intensité lumineuse.



Waschtisch: Contour
 Maße (B x T): 2400 x 460 mm
 Front: 202 Natural Oak
 Korpus: 153 Natural Oak
 Griff: 997 TipOn

—
 Washstand: Contour
 Dimensions (W x D): 2400 x 460 mm
 Front: 202 Natural Oak
 Carcase: 153 Natural Oak
 Handle: 997 TipOn

—
 Vasque: Contour
 Dimensions: 2400 x 460 mm (l x p)
 Façade: 202 Natural Oak
 Corps: 153 Natural Oak
 Poignée: 997 TipOn





Waschtisch: Contour
 Maße (B x T): 1205 x 460 mm
 Fronten: 233 Stormgrey/
 205 Ulme gekälkt
 Korpus: 155 Ulme gekälkt
 Griff: 728 Edelstahlfarbig

Washstand: Contour
 Dimensions (W x D): 1205 x 460 mm
 Fronts: 233 Stormgrey/
 205 White washed elm
 Carcase: 155 White washed elm
 Handle: 728 Stainless steel coloured

Vasque : Contour
 Dimensions : 1205 x 460 mm (l x p)
 Façades : 233 Stormgrey/
 205 Orme blanchi
 Corps : 155 Orme blanchi
 Poignée : 728 Couleur inox





VARIPO



Matt trifft Struktur: Der Farbton Sandbeige und die Holzstruktur Toffee interpretieren aufs Schönste den Naturlook. Spiegel, Griffleisten und Sanitärelemente setzen dazu glänzende Akzente.

Matt meets texture: the sand beige colour shade and the toffee wood texture couldn't interpret the natural look in a more beautiful way. Added to this, mirror, grip ledges and bathroom elements make shining statements.

Mat et structuré : le coloris beige sable et l'imitation bois Toffee interprètent à merveille le look naturel. Le miroir, les poignées profil et les éléments sanitaires apportent à l'ensemble une note brillante.



Waschtisch: Contour
 Maße (B x T): 1205 x 460 mm
 LED-Aufsatzleuchte: Sicilia
 LED-Unterbauleuchte: UL0190S
 Front: 281 Sandbeige matt
 Korpus: 168 Toffee
 Griffleiste: 242 Edelstahlfarbig

Washstand: Contour
 Dimensions (W x D): 1205 x 460 mm
 LED top-mounted light: Sicilia
 LED built-under light: UL0190S
 Front: 281 Sand beige matt
 Carcase: 168 Toffee
 Grip ledge: 242 Stainless steel coloured

Vasque : Contour
 Dimensions : 1205 x 460 mm (l x p)
 Applique DEL : Sicilia
 Luminaire DEL pour pose
 sous éléments : UL0190S
 Façade : 281 Beige sable mat
 Corps : 168 Toffee
 Poignée profil : 242 Couleur inox





Waschtisch: Cubus 2.0
 Maße (B x T): 1212 x 460 mm
 Front: 572 Sabbia matt
 Korpus: 143 Sandbeige matt
 Griff: 790 Messing gebürstet

Washstand: Cubus 2.0
 Dimensions (W x D): 1212 x 460 mm
 Front: 572 Sabbia matt
 Carcase: 143 Sand beige matt
 Handle: 790 Brass, brushed

Vasque : Cubus 2.0
 Dimensions : 1212 x 460 mm (l x p)
 Façade : 572 Sabbia mat
 Corps : 143 Beige sable mat
 Poignée : 790 Laiton brossé





VARI PRO



Zeit für einen glanzvollen Auftritt!
 Unser Glaslaminat hält die Fläche
 hinter dem Waschtisch zuverlässig
 sauber. Handtuchhalter, Armatur und
 Griffe befinden sich dank Messing-
 optik harmonisch im Einklang.



*Time to make a brilliant entrance! Our glass laminate
 reliably keeps everything clean in the area behind the
 washbasin. Finished in brass effect, towel rail, mixer tap
 and handles all harmonise for a consistent look.*

Une mise en scène brillante ! Notre verre
 stratifié garantit la propreté de la surface
 derrière la vasque. Les poignées, robinetterie
 et porte-serviettes, déclinés en aspect laiton,
 sont parfaitement assortis.



VARI PRO



Hier stimmt jedes Detail. Die Akzentfarbe Schwarz unterstreicht den zeitgemäßen Anspruch dieser Badplanung. Bildschön dazu: der schneeweiße Waschtisch **Cubus 2.0**.



Waschtisch: Cubus 2.0
 Maße (B x T): 1212 x 460 mm
 Front: 084 Wild Oak
 Korpus: 160 Schwarz matt
 Griff: 226 Schwarz gepulvert

—
 Washstand: Cubus 2.0
 Dimensions (W x D):
 1212 x 460 mm
 Front: 084 Wild Oak
 Carcase: 160 Black matt
 Handle: 226 Black, powder-coated

—
 Vasque : Cubus 2.0
 Dimensions :
 1212 x 460 mm (l x p)
 Façade : 084 Wild Oak
 Corps : 160 Noir mat
 Poignée : 226 Noir, poudre époxy



*This is where every single detail is just right. Accent colour black underscores the contemporary feel of this bathroom ensemble. A lovely complement: the snow-white **Cubus 2.0** washstand.*



VARI PRO

Ici, tout est parfait jusque dans les moindres détails. La teinte accentuée qu'est le noir sublime le style contemporain de cette salle de bains. La vasque blanche **Cubus 2.0** incarne l'élégance au mieux.





Überzeugend: Die Qualität einer Badplanung zeigt sich an raffinierten Stauraumlösungen und an Details wie zuverlässigen Scharnieren, die über eine integrierte Komfortdämpfung verfügen.

Compelling: the quality of the way in which a bathroom is planned is reflected in clever storage solutions and details such as reliable hinges with integrated, user-friendly soft-closing.

La qualité d'une salle de bains se traduit par des solutions de rangement innovantes et des détails convaincants, tels que les charnières fiables avec amortissement intégré.





Waschtisch: Futura 2
 Maße (B x T): 810 x 555 mm
 LED-Aufsatzleuchte: Elba
 LED-Unterbauleuchte: UL0160S
 Front: 049 Nero/
 308 Greige Hochglanz
 Korpus: 172 Nero/
 742 Greige glänzend
 Griff: 997 TipOn

Waschstand: Futura 2
 Dimensions (W x D):
 810 x 555 mm
 LED surface-mounted lighting: Elba
 LED built-under light: UL0160S
 Front: 049 Nero/
 308 Greige high-gloss
 Carcase: 172 Nero/
 742 Gloss greige
 Handle: 997 TipOn

Vasque : Futura 2
 Dimensions :
 810 x 555 mm (l x p)
 Applique DEL : Elba
 Luminaire DEL pour pose
 sous éléments : UL0160S
 Façade : 049 Nero /
 308 Greige brillant
 Corps : 172 Nero /
 742 Grège brillant
 Poignée : 997 TipOn



VARI PRO



Leuchtendes Beispiel: Die LED-Aufsatzleuchte **Elba** lässt sich dank unseres Lichtsystems **LightMotion** individuell dimmen und bedienen. Die Lichtfarbe kann stufenlos von kalt- zu warmweiß variiert werden.

*Shining example: the **Elba** LED top-mounted light can be controlled and dimmed to any level thanks to our **LightMotion** lighting system. Colour temperature can be continuously varied from cool white to warm white.*

Exemple lumineux : grâce à notre système d'éclairage **LightMotion**, l'applique DEL **Elba** peut être réglée et commandée en fonction des envies personnelles. La température de couleur peut être réglée en continu, du blanc froid au blanc chaud.



Waschtisch: Futura 2
Maße (B x T): 1612 x 460 mm
Front: 011 Weiß matt
Korpus: 196 Grain hell
Griff: 226 Schwarz gepulvert



VARIPO

Washstand: Futura 2
Dimensions (W x D): 1612 x 460 mm
LED top-mounted light: Elba
Front: 011 White matt
Carcase: 196 Grain light
Handle: 2226 Black, powder-coated

Vasque : Futura 2
Dimensions : 1612 x 460 mm (l x p)
Applique DEL : Elba
Façade : 011 Blanc mat
Corps : 196 Grain clair
Poignée : 226 Noir, poudre époxy



Waschtisch: Organic
 Maße (B x T): 810 x 555 mm
 Front: 155 Kito Stahl
 Korpus: 521 Kito Stahl
 Griff: 225 Quarzgrau gepulvert

Washstand: Organic
 Dimensions (W x D): 810 x 555 mm
 Front: 155 Kito steel
 Carcase: 521 Kito steel
 Handle: 225 Quartz grey,
 powder-coated

Vasque : Organic
 Dimensions : 810 x 555 mm (l x p)
 Façade : 155 Kito acier
 Corps : 521 Kito acier
 Poignée : 225 Gris quartz,
 poudre époxy





Antippen genügt: Per Touch Point lässt sich die Lichtstimmung direkt am Spiegel steuern.

A tap is all it takes: the lighting mood can be controlled directly on the mirror via Touch Point.

Il suffit d'effleurer : Touch Point permet de commander l'ambiance lumineuse directement sur le miroir.



Über kurz oder lang komfortabel: Unsere Griffe gibt es in verschiedenen Breiten und Farben – für eine Badmöbelgestaltung mit unverwechselbarer Note.

Practical convenience whether short or long: our handles are available in various widths and colours – for bathroom furniture designed with a touch of distinction.

Toujours conçues pour une bonne prise en main, nos poignées, disponibles en plusieurs largeurs et couleurs, subliment la salle de bains.



Rund trifft eckig: Der schwarze Metallrahmen des Rundspiegels korrespondiert mit der eckigen Form der Griffe. Das Wechselspiel zwischen Korpus und Front setzt auf Kontrastreichtum.

Round meets square: the black metal frame of the round mirror communicates with the square shape of the handles. The interplay between carcass and front sets store by richness of contrast

Cercle et rectangle se rencontrent : le cadre métallique noir du miroir rond est repris par les poignées linéaires. Le jeu entre le corps et la façade mise sur les contrastes frappants.



Waschtisch: Organic 2.0
Maße (B x T): 1212 x 555 mm
Front: 011 Weiß matt
Korpus: 126 Quarzgrau matt
Griffleiste: 252 Schwarz matt
Waschtischplatte: 941 Black burned

—
Washstand: Organic 2.0
Dimensions (W x D): 1212 x 555 mm
Front: 011 White matt
Carcasse: 126 Quartz grey matt
Handle: 252 Black matt
Washstand top panel: 941 Black burned

—
Vasque : Organic 2.0
Dimensions : 1212 x 555 mm (l x p)
Façade : 011 Blanc mat
Corps : 126 Gris quartz mat
Poignée : 252 Noir mat
Plan de vasque : 941 Black burned

Roma –

EDLE GLASWASCHTISCHE

ROMA – CLASSY GLASS WASHBASINS
ROMA – DE NOBLES VASQUES EN VERRE



R o m a
1212, 1412, 1612 mm



R o m a
612-1912 mm

VARI PRO



Trendfarbe Schwarz: Rundspiegel und Badmöbel ergänzen sich perfekt.

On-trend colour black: round mirror and bathroom furniture complement each other perfectly.

Noir, couleur tendance : le miroir rond et les meubles se complètent parfaitement.



Eine patentierte Technologie macht die seidenmatte Oberfläche dieser Front zur Sensation. Sie begeistert mit Pflegeleichtigkeit, warmer Haptik und einem unwiderstehlichen Erscheinungsbild. Dank des speziellen Anti-Fingerprint-Effektes sind Fingerabdrücke auf der Oberfläche mit bloßem Auge nicht oder nur sehr schwach wahrnehmbar.

A patented technology makes the silk matt surface of this front a sensation. It impresses with low maintenance, warm feel and an irresistible look. Thanks to the special anti-fingerprint effect, finger marks on the surface are either invisible or barely noticeable.

Une technologie brevetée procure une sensation de bien-être au contact de la surface mate soyeuse de cette façade. Elle se distingue par son entretien facile, son toucher agréable et par une élégance irrésistible. Grâce au traitement spécial, les traces de doigts sur la surface sont invisibles ou à peine perceptibles.



Anti-Fingerprint-Oberfläche
Anti-fingerprint surface
Traitement anti-traces de doigts



Waschtisch: Roma
Maße (B x T): 812 x 500 mm
Front: 279 schwarz matt
Korpus: 126 Quarzgrau matt
Griff: 997 TipOn

—
Washstand: Roma
Dimensions (W x D): 812 x 500 mm
Front: 279 Black matt
Carcase: 126 Quartz grey matt
Handle: 997 TipOn

—
Vasque : Roma
Dimensions : 812 x 500 mm (l x p)
Façade : 279 Noir mat
Corps : 126 Gris quartz mat
Poignée : 997 TipOn



Waschtisch: Roma
 Maße (B x T): 1012 x 500 mm
 LED-Aufsatzleuchte: Elba
 Front: 069 Concrete grey
 Korpus: 180 Concrete grey
 Griff: 797 Chrom

Washstand: Roma
 Dimensions (W x D): 1012 x 500 mm
 LED top-mounted light: Elba
 Front: 069 Concrete grey
 Carcase: 180 Concrete grey
 Handle: 797 Chrome

Vasque : Roma
 Dimensions : 1012 x 500 mm (l x p)
 Applique DEL : Elba
 Façade : 069 Concrete grey
 Corps : 180 Concrete grey
 Poignée : 797 Chrome

Zeitgemäß in Betonoptik: Waschtisch, Regal und Wandschrank schaffen Stauraum. Praktisch: die Sitzbank mit abnehmbarem Sitzkissen.

Contemporary in concrete look: washstand, shelf unit and wall cabinet create storage space. Practical: the bench with removable cushion.

Aspect béton moderne : la vasque, l'étagère et l'armoire murale optimisent l'espace de rangement. La banquette avec coussin amovible est pratique.



Raffiniertes Detail: die aufsetzbare LED-Leuchte
Elba in Chrom oder Schwarz.

*Lovely detail: **Elba** top-mounted LED light
in chrome or black.*

Judicieuse : l'applique DEL **Elba** chrome ou noire.



Waschtisch: Roma
Maße (B x T): 1012 x 500 mm
Front: 031 Quarzgrau matt
Korpus: 126 Quarzgrau matt
Griff: 224 Arktis gepulvert

Washstand: Roma
Dimensions (W x D): 1012 x 500 mm
Front: 031 Quartz grey matt
Carcase: 126 Quartz grey matt
Handle: 224 Arctic,
powder-coated

Vasque : Roma
Dimensions : 1012 x 500 mm (l x p)
Façade : 031 Gris quartz mat
Corps : 126 Gris quartz mat
Poignée : 224 Arctique,
poudre époxy





VARI PRO

Strahlende Aussichten: Der Spiegelschrank mit den seitlichen LED-Profilen und der optionalen Waschtischbeleuchtung garantiert optimale Lichtverhältnisse.

Radiant prospects: the mirror cabinet with LED profiles down either side and optional washbasin lighting guarantees optimum illumination at the washbasin.

De belles perspectives : les bandes DEL de chaque côté de l'armoire à glace et l'éclairage en option au niveau de la vasque offrent une lumière parfaite.

MÖBELKLASSIKER UND Markenkeramik





Waschtisch: Villeroy Boch Subway 2.0
 Maße (B x T): 1000 x 470 mm
 LED-Aufsatzleuchte: SOL
 Front: 574 Piano matt
 Korpus: 160 Schwarz matt
 Griff: 271 Chrom

—
 Washstand: Villeroy Boch Subway 2.0
 Dimensions (W x D): 1000 x 470 mm
 LED top-mounted light: SOL
 Front: 0574 Piano matt
 Carcase: 160 Black matt
 Handle: 271 Chrome

—
 Vasque : Villeroy Boch Subway 2.0
 Dimensions : 1000 x 470 mm (l x p)
 Applique DEL : SOL
 Façade : 574 Piano mat
 Corps : 160 Noir mat
 Poignée : 271 Chrome

PLUS

FURNITURE CLASSICS
 AND BRAND-NAME CERAMICS
 MEUBLES CLASSIQUES
 ET CÉRAMIQUE DE MARQUE



Unser Sortiment bietet Ihnen eine vielfältige Auswahl hochwertiger Unterbauten für die Waschtischserien namhafter Keramikhersteller. Sollten Sie Ihren Wunschwaschtisch nicht finden, sprechen Sie bitte Ihren Fachhändler an. Wir fertigen individuelle Möbel nach Maß – und begleiten Sie gern persönlich auf dem Weg zu Ihrem Wunschwaschtisch!

Our range features a diverse selection of high-quality built-under units for the washstand ranges from renowned ceramics manufacturers. If you are not able to find the washstand you would like, please contact your specialist retailer. We also produce furniture tailored to your requirements – and would be happy to accompany you on the path to your chosen washstand!

Notre gamme vous propose un grand choix de meubles bas pour les vasques de céramistes renommés. Si vous ne trouvez pas la vasque recherchée, veuillez vous adresser à votre revendeur spécialisé. Nous fabriquons des meubles individuels sur mesure et vous conseillons volontiers personnellement pour vous aider à trouver votre vasque souhaitée !



Villeroy & Boch

1748

■ GEBERIT

DURAVIT

LAUFEN



Ideal Standard



Für welchen Markenwaschtisch wir Unterschränke anbieten, erfahren Sie unter:
www.badea-badmoebel.de/classic-plus
Eine Übersicht wird stetig aktualisiert und erweitert.

*Find out which brand washstands we offer base units for at:
www.badea-badmoebel.de/classic-plus-en
This overview is constantly updated and extended.*

Pour savoir quel meuble bas convient à quelle vasque de marque, voir :
www.badea-badmoebel.de/classic-plus-fr
Ce récapitulatif est toujours actualisé et élargi.



Im Mittelpunkt: Mit dem Plus Programm entstehen Badwunder um hochwertige Markenwaschtische. Formvollendet passt sich die schwarze Schrankausführung mit individueller Finesse an.

Taking centre stage: the Plus range creates wonderful bathrooms centred around high-quality brand-name washbasins. Perfecting the whole design, the black cabinet finish reflects a level of finesse second to none.

Le programme Plus sublime la salle de bains autour de vasques exclusives. La finition noire du meuble mise sur un contraste subtil.

Minimalistische Regale
rahmen Utensilien ein
und füllen Wände
ästhetisch aus.

*Minimalist shelves provide
a frame for utensils and fill
walls with aesthetic appeal.*

Les étagères, parfaites
pour habiller le mur,
encadrent les ustensiles
indispensables.



Visit –

MINERALGUSSWASCHTISCHE

VISIT – CAST MINERAL WASHBASINS
VISIT – VASQUES FONTE MINÉRALE



Visit 1
405, 505 mm



Visit 2
400 mm



Visit 3
505 mm



Visit – KERAMIKWASCHTISCHE

VISIT – CERAMIC WASHBASINS
VISIT – VASQUES EN CÉRAMIQUE

N



Visit 4
454 mm

N



Visit 4
454 mm

VISIT

Kompakte Waschtische aus dem Programm Visit machen in Gästebädern eine kleine, aber feine Figur bei hervorragender Materialverarbeitung.

Exquisite material finish leaves compact washbasins from the Visit range to cut a small but fine figure in guest bathrooms.

Les vasques compactes Visit, qui se distinguent par leur excellente finition, ont fière allure dans les salles d'eau d'invités.

Visit

DAS BESTE FÜR GÄSTE



VISIT – THE BEST FOR GUESTS
VISIT – LE MEILLEUR POUR LES INVITÉS



Visit 1

Maße (B x T): 405 x 305 mm, 505 x 405 mm

—
Dimensions (W x D): 405 x 305 mm, 505 x 405 mm

—
Dimensions : 405 x 305 mm, 505 x 405 mm (l x p)

Visit 2

Maße (B x T): 400 x 220 mm

—
Dimensions (W x D): 400 x 220 mm

—
Dimensions : 400 x 220 mm (l x p)



Visit 3

Maße (B x T): 505 x 355 mm

—
Dimensions (W x D): 505 x 355 mm

—
Dimensions : 505 x 355 mm (l x p)

Visit 4

schwarz/weiß

Maße (B x T): 454 x 250 mm

—
black/white

Dimensions (W x D): 454 x 250 mm

—
noir/blanc

Dimensions : 454 x 250 mm (l x p)





Waschtisch: Visit 4
Maße (B x T x H): 454 x 250 x 125 mm
Front: 251 Black blue
Korpus: 521 Kito Stahl
Knopf: 129 Edelstahlfarbig

—
Washstand: Visit 4
Dimensions (W x D x H): 454 x 250 x 125 mm
Front: 251 Black blue
Carcase: 521 Kito steel
Knob: 129 Stainless steel coloured

—
Vasque : Visit 4
Dimensions : 454 x 250 x 125 mm (l x p x h)
Façade : 251 Black blue
Corps : 521 Kito acier
Bouton : 129 Couleur inox



VISIT





Design in Vollendung: Vom schwarzen Möbelwaschtisch über das geräumige ERRE8-Regal bis zum dezenten Stützfuß überzeugt jedes Detail. Ideal für kreative Impulse im modernen Badezimmer.

Design perfection: from the black top-mounted washbasin and spacious ERRE8 shelf element to the understated support leg, every detail is utterly compelling. Ideal for inspirational creativity in the modern bathroom.

Design à la perfection : de la vasque sur plan noire au pied de support discret en passant par le meuble étagère ERRE8 spacieux, tout a été prévu jusque dans les moindres détails. Idéal pour la créativité dans la salle de bains moderne.



Visit –

KERAMIKAUFSATZWASCHTISCHE

VISIT – CERAMIC COUNTERTOP WASHBASINS

VISIT – VASQUES À POSER EN CÉRAMIQUE



Pisa
550 x 360 mm



Livorno
510 x 380 mm



Monza
370 mm



Bari
Ø 360 mm



Bari
Ø 360 mm

Visit —

GLASAUFSATZWASCHTISCH

VISIT — GLASS COUNTERTOP WASHBASINS
VISIT — VASQUES À POSER EN VERRE



Rimini
Ø 390 mm

VISIT



Sanft schimmernd: Die Glaslamiat-Front mit Griffleiste begeistert mit zeitloser Schönheit. Genauso geradlinig präsentiert sich die LED-Aufsatzleuchte **Capri**, die sich dank **LightMotion** in Helligkeit und Lichtfarbe individuell regulieren lässt.

*Gently shimmering: the glass laminate front with grip ledge enthalls with timeless beauty. Equally as sleek is the **Capri** LED top-mounted light which, thanks to **LightMotion**, can be adjusted in brightness and colour temperature to suit any preference.*



Légers reflets : la façade en verre stratifié dotée d'une poignée profil séduit par sa beauté intemporelle. L'applique DEL **Capri**, dont l'intensité lumineuse et la température de couleur peuvent être réglées grâce à **LightMotion**, affiche elle aussi des formes linéaires.

Waschtisch: Bari
 Maße: Ø 360 mm
 LED-Aufsatzleuchte: Capri
 Front: 027 Black burned / 575 Aureo matt
 Korpus: 166 Black burned
 Griffleiste: 242 Edelstahlfarbig
 Waschtischplatte: 941 Black burned

—
 Washstand: Bari
 Dimensions: Ø 360 mm
 LED top-mounted light: Capri
 Front: 027 Black burned / 575 Aureo matt
 Carcase: 166 Black burned
 Grip ledge: 242 Stainless steel coloured
 Washstand top panel: 941 Black burned

—
 Vasque : Bari
 Dimensions : Ø 360 mm
 Applique DEL : Capri
 Façade : 027 Black burned / 575 Aureo mat
 Corps : 166 Black burned
 Poignée profil : 242 Couleur inox
 Plan de vasque : 941 Black burned



QUALITÄT ZÄHLT bis ins Detail



Gebündeltes Know-how und die über 25-jährige Erfahrung unseres Teams haben die Grundlage für eines der erfolgreichsten Badmöbel-Programme geschaffen: Bei badea zählt jedes noch so kleine Detail und jedes Ausstattungselement hat zahlreiche Prüfungen erfolgreich bestanden. Vertrauen Sie auf badea-Markenqualität „Made in Germany“.

*QUALITY MATTERS IN EVERY LAST DETAIL
Our team's concentrated expertise and over 25 years of experience have created the basis for one of the most successful bathroom furniture ranges there are: at badea, every detail matters and every element featured has successfully passed numerous tests. Put your trust and confidence in badea brand quality "Made in Germany".*

QUALITÉ JUSQUE DANS LES MOINDRES DÉTAILS

Ce concentré de savoir-faire conjugué à plus de 25 ans d'expérience constitue la base de l'une des plus célèbres collections de salles de bains : aucun détail, si petit soit-il, n'échappe à badea et chaque équipement a subi de nombreux tests. Faites confiance à la marque badea « Made in Germany ».



PFLEGEHINWEISE
CARE ADVICE
CONSEILS D'ENTRETIEN

TECHNIK VON BLUM



Unsere Innenausstattung ist grundsätzlich gedämpft. Wir liefern ANTARO-Schubkästen und Auszüge in Oriongrau als Vollauszüge mit farblich abgestimmtem Kosmetikeinsatz.

TECHNOLOGY BY BLUM

All of our interior fittings come with soft-closing function. We supply ANTARO drawers and pull-outs in Orion grey on full-extension runners with make-up insert in matching colour.

TECHNIQUE BLUM

En règle générale, notre équipement intérieur est freiné. Les tiroirs et coulissants ANTARO, à sortie totale, sont disponibles en gris Orion et complétés d'inserts pour produits de beauté assortis.

LINEAR-MONTAGEPLATTEN

Die Linear-Montageplatte versteckt sich dezent hinter dem Scharnier. Dadurch sind keine Montageschrauben sichtbar. Der millionenfach bewährte Clip-Mechanismus steht für eine einfache und werkzeuglose Scharniermontage.

LINEAR MOUNTING PLATES

The linear mounting plate is discreetly hidden behind the hinge. As a result, no mounting screws are visible. Tried and tested a million times and more, the clip mechanism is synonymous with simple and tool-free hinge mounting.

PLAQUES DE MONTAGE LINÉAIRES

La plaque de montage linéaire étant dissimulée derrière la charnière, aucune vis de montage n'est visible. Le mécanisme Clip, éprouvé à maintes reprises, assure un montage simple et sans outil des charnières.



DREHSCHARNIER CLITOP BLUMOTION



Unsere Türen sind serienmäßig mit Dämpfung ausgestattet. Diese kann bei Bedarf ganz ohne Werkzeug am Scharnier deaktiviert werden.

CLITOP BLUMOTION DOOR HINGE

Our doors feature soft-closing function as standard. Whenever necessary, this can be deactivated on the hinge without the need for any tools.

CHARNIÈRE CLITOP BLUMOTION

Nos portes sont équipées en série d'un amortissement. Le cas échéant, il est possible de le désactiver sans outil au niveau de la charnière.

VIelfALT AN Möglichkeiten



Entdecken Sie die vielen Möglichkeiten: von Schichtstoff bis UV-Lack in Hochglanz – bei badea haben Sie die Wahl aus 38 verschiedenen Frontausführungen. Ihr Badfachmann berät Sie gern zu den Gestaltungsmöglichkeiten nach Maß.

SO MANY OPTIONS
Discover the many options: from laminate to UV lacquer in high-gloss – at badea you can choose from 38 different front finishes. Your bathroom specialist will be pleased to advise you on the many made-to-measure design options.

DE NOMBREUSES POSSIBILITÉS
Découvrez les nombreuses possibilités : du stratifié à la laque UV brillante, badea vous propose 38 décors façade. Demandez conseil à votre revendeur.

**PG 1 DICKKANTENFRONT:
SPANPLATTENKERN**
Fronten mit Spanplattenkern, einer beidseitigen,
dekorativen Melaminharzbeschichtung und
umlaufender Kunststoffdickkante.

PG 2 UV LACK HG: MDF-KERN
Fronten mit MDF-Kern und rundum verlaufender
Kunststoffdickkante. Vorderseitig mehrfach mit
hochwertigem UV-Lack beschichtet und nach jedem
Lackiervorgang mit energiereichem UV-Licht
ausgehärtet.

**PG 3 MEHRBLATTAUFBAU
DICKKANTENFRONT: SPANPLATTENKERN**
Fronten mit Spanplattenkern und einer Oberfläche,
die durch ihren mehrschichtigen Aufbau härter und
extrem widerstandsfähig ist. Kreative Optionen durch
abgerundete Kanten und fugenlose Optik.

**PG 1 THICK-EDGE FRONT:
PARTICLE-BOARD CORE**
*Fronts with particle board core, decorative melamine resin
coating on both sides and all-round laminate thick edging.*

PG 2 UV LACQUER HG: MDF CORE
*Fronts with MDF core and all-round laminate thick edging.
Multiple coats of high-quality UV lacquer are applied to
the front and cured with high-energy UV light after each
lacquering cycle.*

**PG 3 THICK-EDGE FRONT IN MULTI-PLY
DESIGN: PARTICLE BOARD CORE**
*Fronts with particle-board core and a surface that is
harder and extremely hard-wearing by virtue of its
multiply-ply structure. Creative options thanks to
rounded edges and a seamless look.*

**GP 1 FAÇADE CHANT ÉPAIS :
NOYAU EN PANNEAUX DE PARTICULES**
Façades avec un noyau en panneaux de particules, un
revêtement mélaminé décoratif de chaque côté et un
chant épais en PVC tout autour.

**GP 2 LAQUE UV BRILLANTE :
NOYAU MDF**
Façades avec un noyau MDF et un chant épais en PVC tout
autour. La face avant est revêtue de plusieurs couches de
laque UV exclusive, un rayonnement UV d'une grande
intensité permet d'obtenir une polymérisation complète
après chaque application.

**GP 3 FAÇADE CHANT ÉPAIS,
MULTICOUCHES : NOYAU EN
PANNEAUX DE PARTICULES**
Façades avec un noyau en panneaux de particules et une

**PG 4 MATRIXLACK-FRONT:
SPANPLATTENKERN**
Fronten mit Spanplattenkern und umlaufender
Kunststoffdickkante. Die Oberflächen sind
beidseitig mit gehärtetem Mattlack beschichtet:
Flüssigkeiten, Chemikalien und Fingerabdrücke
werden zuverlässig abgewiesen.

**PG 5 GLASLAMINAT-FRONT:
MDF-KERN**
Fronten mit MDF-Kern, samtweicher Haptik
und spezieller antibakterieller Beschichtung.
Beidseitig vollendet mit farbgebender Polymer-
schicht, polymerem Glas und kratzbeständigem
Hardcoat.

**PG 4 MATRIX LACQUER FRONT:
PARTICLE-BOARD CORE**
*Fronts with particle board core and all-round laminate
thick edging. The surfaces are coated on both sides
with hardened matt lacquer: liquids, chemicals and
finger marks are reliably repelled.*

**PG 5 GLASS LAMINATE FRONT:
MDF CORE**
*Fronts with MDF core, velvety-soft feel and special
anti-bacterial coating. Finished on both sides with
a polymer colourant, polymer glass and scratch-
resistant hard coat.*

surface très dure et extrêmement résistante grâce à sa
structure multicouches. Chants arrondis et look sans joint
pour laisser libre cours à sa créativité.

**GP 4 FAÇADE LAQUE MATRIX :
NOYAU EN PANNEAUX DE PARTICULES**
Façades avec un noyau en panneaux de particules et
un chant épais en PVC tout autour. Les surfaces sont
revêtues de chaque côté de laque mate durcie : les
liquides, les traces de doigts ni les produits chimiques
ne peuvent adhérer.

**GP 5 FAÇADE EN VERRE STRATIFIÉ :
NOYAU MDF**
Façades avec un noyau MDF, toucher agréable et
revêtement spécial antibactérien. Couche polymère
colorante de chaque côté, verre polymère et
revêtement dur résistant aux rayures.

PREISGRUPPE 1

PRICE GROUP 1

GROUPE DE PRIX 1

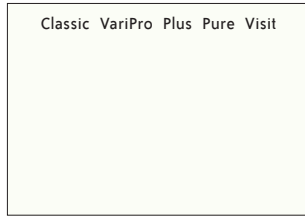

F: 011 | K: 516
Weiß matt
White matt
Blanc mat



F: 027 | K: 166 | W: 941
Black burned waagerecht
Black burned horizontal
Black burned horizontal

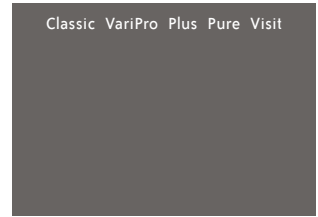

F: 031 | K: 126
Quarzgrau matt
Quartz grey matt
Gris quartz mat

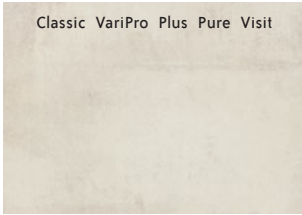

F: 032 | K: 162 | W: 890
Concrete white

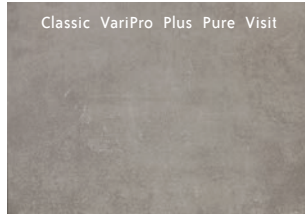

F: 069 | K: 180 | W: 889
Concrete grey



F: 070 | K: 196 | W: 882
Grain hell waagerecht
Grain light horizontal
Grain clair horizontal



F: 084 | K: 191 | W: 967
Wild Oak waagerecht
Wild Oak horizontal
Wild Oak horizontal

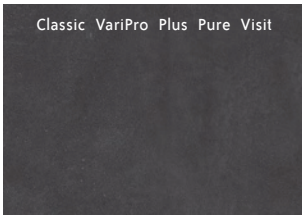

F: 155 | K: 521 | W: 960
Kito Stahl
Kito steel
Kito acier

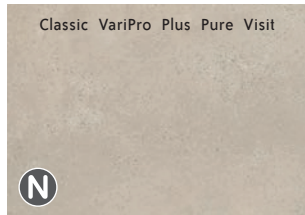

F: 158 | K: 527 | W: 979
Sand
Sand
Sable



F: 202 | K: 153 | W: 942
Natural Oak waagerecht
Natural Oak horizontal
Natural Oak horizontal



F: 203 | K: 154 | W: 953
Alpine Oak waagerecht
Alpine Oak horizontal
Alpine Oak horizontal



F: 205 | K: 155 | W: 952
Ulme gekälkt waagerecht
Elm limed horizontal
Orme blanchi horizontal

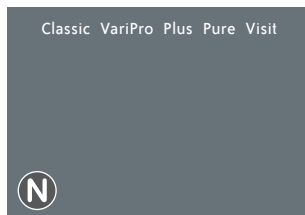

F: 233
Stormgrey



F: 234 | K: 127
Greige matt
Greige matt
Greige mat

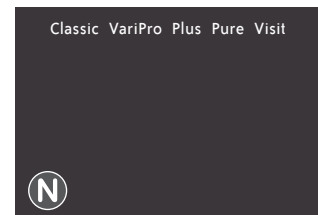

F: 236 | K: 117
Carbon matt
Carbon matt
Carbon mat

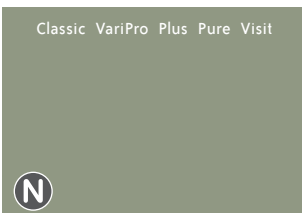

F: 237 | K: 734
Salbei
Sage
Sauge

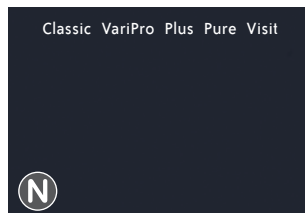

F: 251
Black blue

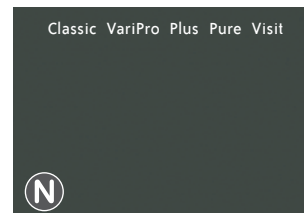

F: 252
Black green

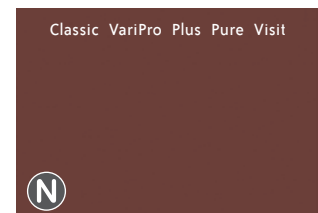

F: 253
Acai

PREISGRUPPE 2

PRICE GROUP 2

GROUPE DE PRIX 2



F: 034 | K: 163
Quarzgrau Hochglanz
Quartz grey high-gloss
Gris quartz brillant

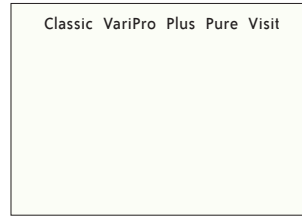

F: 098 | K: 165 | W: 910
Weiß Hochglanz
White high-gloss
Blanc brillant



F: 300 | K: 727
Sandbeige Hochglanz
Sand beige high-gloss
Beige sable brillant



F: 308 | K: 742
Greige Hochglanz
Greige high-gloss
Greige brillant

PREISGRUPPE 3

PRICE GROUP 3

GROUPE DE PRIX 3



F: 018 | K: 179
Caramel waagerecht
Caramel horizontal
Caramel horizontal



F: 028 | K: 167
Dartmoor waagerecht
Dartmoor horizontal
Dartmoor horizontal



F: 029 | K: 168
Toffee waagerecht
Toffee horizontal
Toffee horizontal



F: 048 | K: 170
Maroni waagerecht
Maroni horizontal
Maroni horizontal

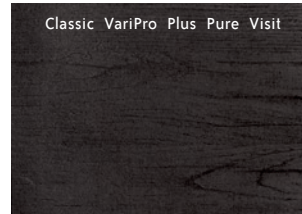

F: 049 | K: 172
Nero waagerecht
Nero horizontal
Nero horizontal

PREISGRUPPE 4

PRICE GROUP 4

GROUPE DE PRIX 4

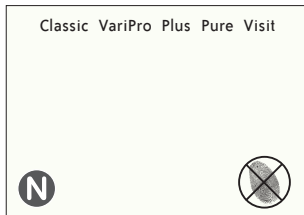

F: 275 | K: 516
Weiß matt
White matt
Blanc mat

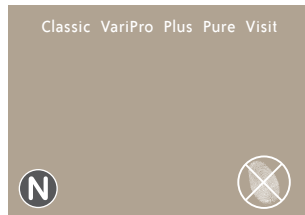

F: 276 | K: 127
Greige matt
Greige matt
Greige mat



F: 277 | K: 126
Quarzgrau matt
Quartz grey matt
Gris quartz mat

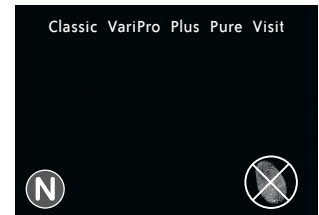

F: 279 | K: 160
Schwarz matt
Black matt
Noir mat

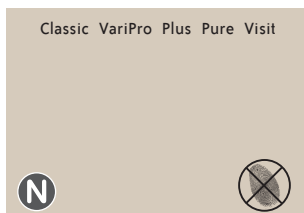

F: 281 | K: 143
Sandbeige matt
Sand beige matt
Beige sable mat

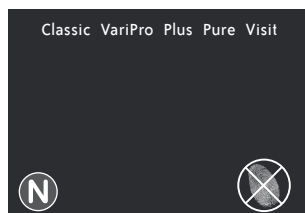

F: 288 | K: 117
Carbon matt
Carbon matt
Carbon mat

PREISGRUPPE 5

PRICE GROUP 5

GROUPE DE PRIX 5

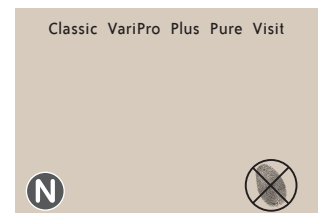

F: 572 | W: 702
Sabbia matt
Sabbia matt
Sabbia mat

Programm/Program/Programmes :
Classic, VariPro, Plus, Pure, Visit

F: Front
Front
Façade

K: Korpus
Carcase
Corps

W: Waschtischplatte
Washstand plate
Plan de vasque



Anti-Fingerprint-Oberfläche
Anti-fingerprint surface
Traitement anti-traces de doigts

PREISGRUPPE 5

PRICE GROUP 5

GROUPE DE PRIX 5

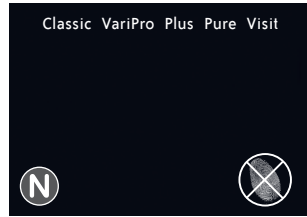

F: 574 | W: 704

Piano matt
Piano matt
Piano mat



F: 575 | W: 705

Aureo matt
Aureo matt
Aureo mat



F: 576 | W: 706

Titanio matt
Titanio matt
Titanio mat

WASCHTISCHPLATTEN WASHSTAND TOPS PLANS DE VASQUE

16, 25 UND 39 MM STÄRKE

THICKNESS 16, 25 AND 39 MM
16, 25 ET 39 MM D'ÉPAISSEUR



882
Grain hell
Grain light
Grain clair

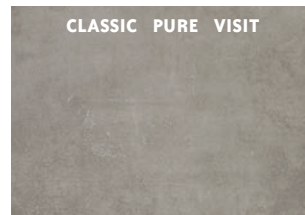

889
Concrete grey

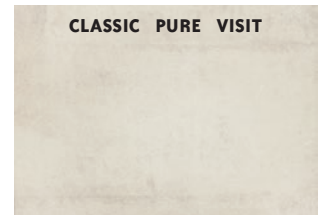

890
Concrete white

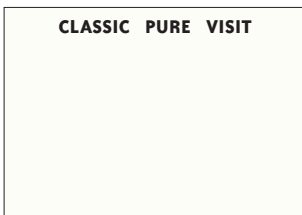

910
Weiß glänzend
White gloss
Blanc brillant

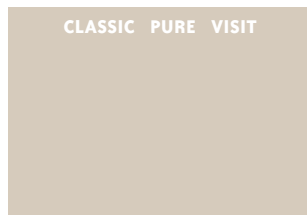

915
Sandbeige matt
Sand beige matt
Beige sable mat



941
Black burned



942
Natural Oak



952
Ulme gekälkt
Elm limed
Orme blanchi



953
Alpine Oak
Alpine Oak
Alpine Oak



960
Kito Stahl
Kito steel
Kito acier



961
Skyfall



962
MoCCA

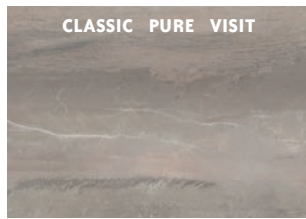

965
Quartz Rosé
Quartz rosé
Quartz rosé



967
Wild Oak

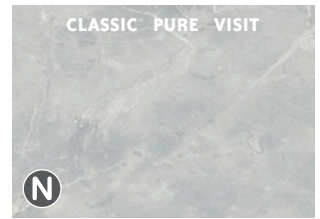

969
Marmor Grigio

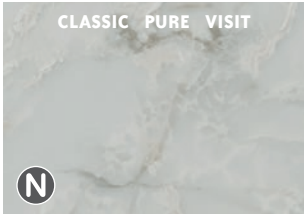

970
Marmor Bianco

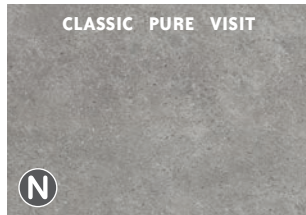

971
Moon

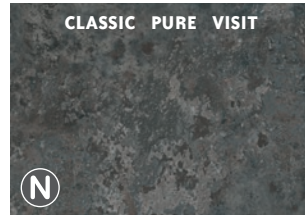

976
Green Slade

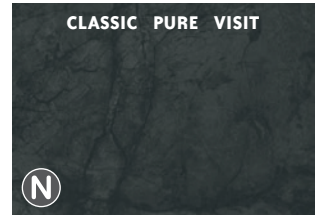

978
Marmor Nero

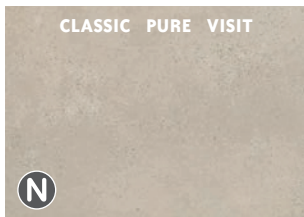

979
Sand
Sand
Sable

16 MM STÄRKE
THICKNESS 16 MM
16 MM D'ÉPAISSEUR

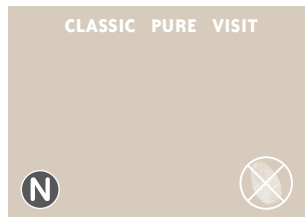

702
Sabbia matt
Sabbia matt
Sabbia mat

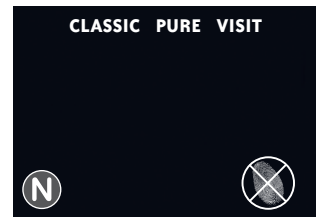

704
Piano matt
Piano matt
Piano mat

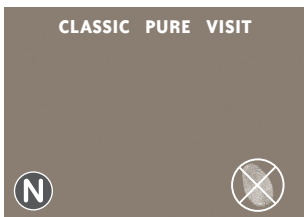

705
Aureo matt
Aureo matt
Aureo mat

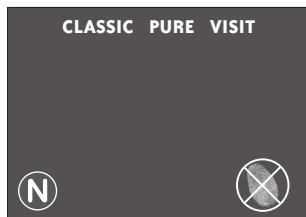

706
Titanio matt
Titanio matt
Titanio mat

12 MM STÄRKE
THICKNESS 12 MM
12 MM D'ÉPAISSEUR

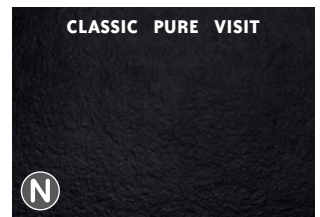

294
Steinstruktur Schwarz
Stone structure black
Structure minérale noire

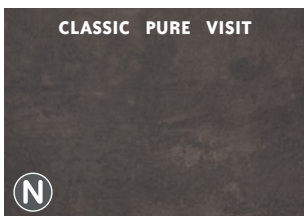

840
Steinstruktur Achat
Stone structure Achat
Structure minérale Achat

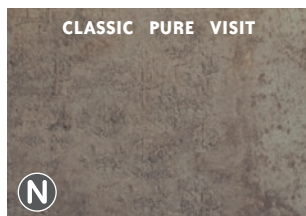

841
Steinstruktur Patina
Stone structure Patina
Structure minérale Patina

Programm/Program/Programmes :
Classic, VariPro, Plus, Pure, Visit

F: Front
Front
Façade

K: Korpus
Corpus
Carcase
Corps

W: Waschtischplatte
Washstand plate
Plan de vasque



Anti-Fingerprint-Oberfläche
Anti-fingerprint surface
Traitement anti-traces de doigts

GRIFFE HANDLES POIGNÉES



Nr. 122 CLASSIC VARIPRO PLUS VISIT

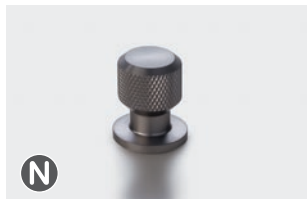

N

Nr. 129 CLASSIC VARIPRO PLUS VISIT



Nr. 217* CLASSIC VARIPRO PLUS VISIT



Nr. 224* CLASSIC VARIPRO PLUS VISIT

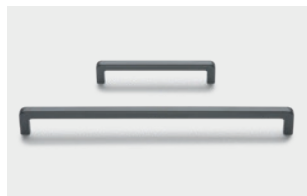

Nr. 225* CLASSIC VARIPRO PLUS VISIT



Nr. 226* CLASSIC VARIPRO PLUS VISIT



Nr. 263* CLASSIC VARIPRO PLUS VISIT

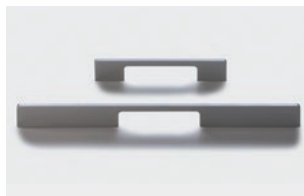

Nr. 266* CLASSIC VARIPRO PLUS VISIT

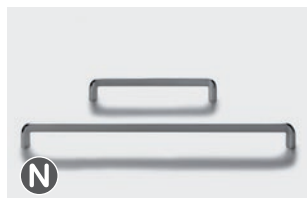

N

Nr. 271* CLASSIC VARIPRO PLUS VISIT



N

Nr. 272* CLASSIC VARIPRO PLUS VISIT



N

Nr. 276* CLASSIC VARIPRO PLUS VISIT



Nr. 511 CLASSIC VARIPRO PLUS VISIT



N

Nr. 515 CLASSIC VARIPRO PLUS VISIT



N

Nr. 516 CLASSIC VARIPRO PLUS VISIT



N

Nr. 716 CLASSIC VARIPRO PLUS VISIT



N

Nr. 728 CLASSIC VARIPRO PLUS VISIT



N

Nr. 756 CLASSIC VARIPRO PLUS VISIT

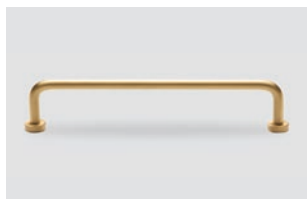

Nr. 790 CLASSIC VARIPRO PLUS VISIT



Nr. 797 CLASSIC VARIPRO PLUS VISIT

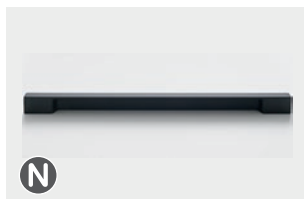

N

Nr. 802 CLASSIC VARIPRO PLUS VISIT



N

Nr. 803 CLASSIC VARIPRO PLUS VISIT

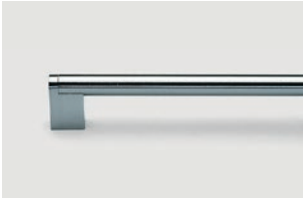

Nr. 230 CLASSIC VARIPRO PLUS VISIT



Nr. 604 CLASSIC VARIPRO PLUS VISIT



Nr. 665 CLASSIC VARIPRO PLUS VISIT



Nr. 997 CLASSIC VARIPRO PLUS VISIT
TipOn



Nr. 242 CLASSIC VISIT



Nr. 243 CLASSIC VISIT



Nr. 252 CLASSIC VISIT



Nr. 253 CLASSIC VISIT

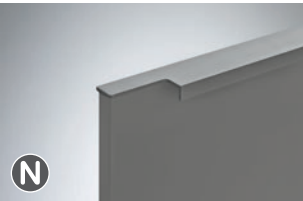

Nr. 254 CLASSIC VISIT



Nr. 298 CLASSIC VISIT



* ab einer Frontbreite von 600 mm wird der lange Griff (320 mm) geliefert, alles darunter wird der kurze Griff mit 160 mm Länge geliefert!
* the long handle (320 mm) is supplied for fronts in a width of 600 mm and over, fronts in narrower widths are fitted with the short handle in 160 mm length.
* à partir d'une largeur de façade de 600 mm, la poignée longue de 320 mm sera livrée, en deçà, la poignée courte de 160 mm !

HANDTUCHHALTER

TOWEL RAILS

PORTE-SERVIETTES



HHS01132 325 mm



HHS01232 325 mm



HHS08140C 400 mm



HHS07132C 320 mm
HHS07138C 380 mm

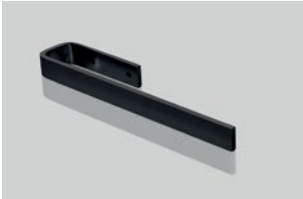

HHS07132S 320 mm
HHS07138S 380 mm



HHS07132W 320 mm
HHS07138W 380 mm



HHS07132M 320 mm
HHS07138M 380 mm

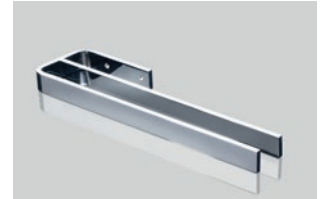

HHS07238C 380 mm

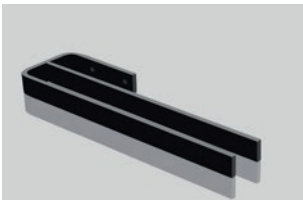

HHS07238S 380 mm

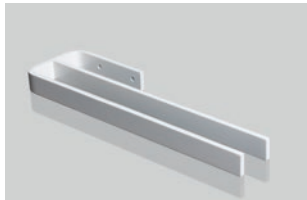

HHS07238W 380 mm



HHS07238M 380 mm



HHSW01142C 420 mm



HHSW01142S 420 mm



HHSW01242C 420 mm

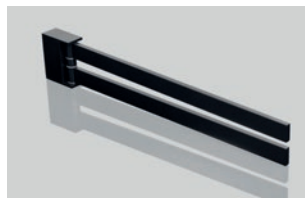

HHSW01242S 420 mm

ARMATUREN

MIXER TAPS ROBINETTERIE



A04C TIBER Chrom



A04S TIBER Schwarz matt



A05C KONGO Chrom



A05S KONGO Schwarz matt



A06C AMAZONAS Chrom



A06S AMAZONAS Schwarz matt



A06M AMAZONAS messingfarbig



A07C COLORADO Chrom



A08C NIL Chrom
für Aufsatzwaschtische
for countertop washstands
pour vasques à poser



A09C NIL Chrom



A10C HUDSON RIVER Chrom



A11C WT 11 Chrom



A11S WT 11 Schwarz matt



A12C WT 11 XL Chrom
für Aufsatzwaschtische
for countertop washstands
pour vasques à poser



A12S WT 11 XL Schwarz matt
für Aufsatzwaschtische
for countertop washstands
pour vasques à poser

Überlauflochabdeckung
für Keramikwaschtische

Overflow cover for
ceramic washstands

Cache de trop-plein pour
vasques en céramique



UA01C Chrom



UA01S Schwarz

**Virtueller Showroom**

Virtual showroom
Showroom virtuel

**Online-Katalog**

Online catalogue
Catalogue en ligne

**Badea Badmöbel**

Bauformat Küchen GmbH & Co. KG
Kattwinkel 1
32584 Löhne - Germany
badea@bauformat.de